



**Produkt handbook
Hydraulische Stein- und Betonspaltgeräte**

**Product Manual
Hydraulic rock and concrete splitters**

**Manuel du produit
Éclateur hydraulique de roc et de béton**

**Manual del producto
Quebrantador hidráulico de roca y hormigón**

**Manual do produto
Quebrador hidráulico de rocha e betão armado**

**Manuale del prodotto
Impianti idraulici spaccarocchia**

**Produkt handbok
Hydrauliskt berg- och betongspräcknings aggregat**

**Tuotekäsikirja
Hydraulinen kivenja betoninhalkoisulaite**

**Product handboek
Hydraulische steen en beton splitters**

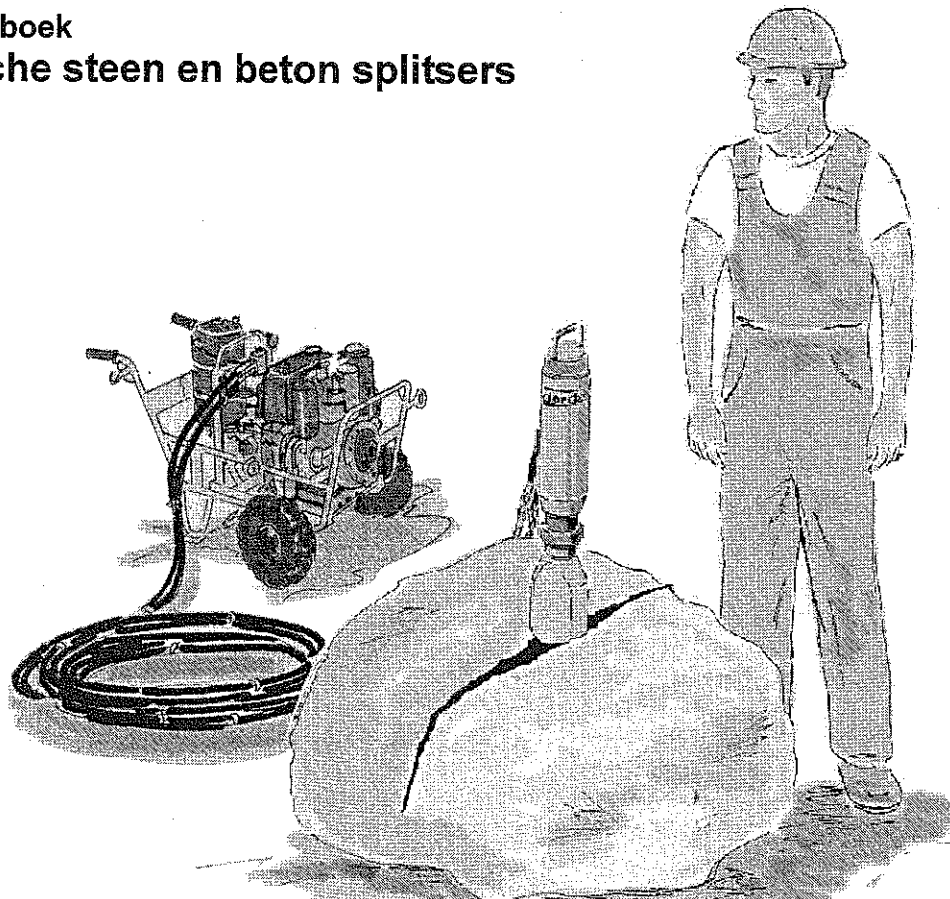

1 Introduction

1.1 Preface

Dear Customer, Dear Operator

You are responsible for

- commissioning,
- maintaining and,
- as necessary, converting

type C hydraulic rock and concrete splitter(s).

This manual is intended to provide you with the information required to carry out these important tasks.

- Please read this manual carefully
- Act exactly in accordance with the descriptions provided
- Be absolutely certain to heed the safety instructions

We will be happy to answer any questions you may have. The telephone / fax numbers, as well as the email and Internet addresses can be found on the first page of this manual.

Kind regards,

Darda Systemtechnik GmbH

1.2 General Product Information

Darda type C splitting cylinders are designed to split natural rock and concrete, a function that, with the use of hydraulics, is accomplished with the utmost precision, environmental friendliness and cost effectiveness.

Whereas traditional methods of rock blasting are accompanied by complex, high cost safety precautions, the safety requirements entailed by this technique are reduced to a minimum.

1.3 Receiving Inspection

- Immediately after unpacking inspect
 - the delivery for transport damage and deficiencies.
 - the completeness of the delivery with reference to the delivery note.
 - any accessories included in the delivery.
- Make certain that no parts remain in the packaging and dispose of the packaging in accordance with the national or regional regulations if there is no reason for complaint.

1.4 Complaints

Damage claims arising from transport damage will only be honoured if the delivery company is notified immediately.

- Immediately fill out a damage report for the returned shipment (due to transport damage / repairs) and sent the parts back to the manufacturing plant in their original packaging, if possible.
- Enclose the following details in the returned shipment:
 - Name and address of the sender and recipient
 - Type, Ser. No.
 - Description of the defect
 - In case of transport damage: delivery company name and exact time of delivery, if possible, driver name and registration number of the delivery vehicle

1.5 Guarantee and Liability

In principle, our **General Sales and Delivery Conditions** apply to the use of the splitting cylinders.

Agreements that deviate from these have to be agreed in writing and confirmed by us!

Guarantee and liability claims in respect of personal injury or damage to property will not be honoured if they arise from one or more of the following causes:

- use of the splitting cylinder for purposes other than those intended
- incorrect connection, commissioning, operating, repair and maintenance of the splitting cylinder
- use of the splitting cylinder with defective safety equipment or incorrectly installed or non-functioning protective equipment
- non-observance of the advice given in this manual in respect of safety, commissioning, operation, repair and maintenance of the splitting cylinders
- structural modifications to the splitting cylinder, made without authorisation
- use of the splitting cylinder with hydraulic power units which are not released for use by Darda
- overheating of the splitting cylinder or the hydraulic oil caused by unsuitable use of the splitting cylinder
- unauthorised modification of the pressure limiting valve setting on the hydraulic power unit and/or the increasing of the hydraulic pressure
- insufficient monitoring and maintenance of wear-and-tear parts, e.g. splitting wedge, counter wedges, enlarging counter wedges, seals
- insufficient lubrication of the wedge sets or use of a lubricating agent other than the special lubricant from Darda
- Emergencies caused by foreign bodies and acts of God.

Guarantee rights and liability claims in respect of damage to components, particularly wedge sets, hydraulic hoses and connections, which cannot be proved to have been caused by manufacturing error are explicitly excluded. Only original Darda accessories may be used for maintenance of the splitting cylinders.



1.6 Product Identification

The descriptions in this manual refer to Type C2S, C4S, C9, C10S and C12 splitting cylinders from **Darda Systemtechnik GmbH**.



The splitting cylinders are available in various models, which are recognisable from the additional letter added to the product name. This additional letter describes the wedge set used, e.g. "N" for the standard wedge set.

1.7 Declaration of Conformity

The machine bearing the designation and serial number shown on the title page was designed and manufactured by **DARDA-Systemtechnik** in accordance with the safety requirements generally applicable to machines laid down in EU Directive 89/392/EEC.

The following harmonized standard, applicable to machines, was used accordingly:
EN 292
(Safety of machines, instruments and systems)

Manufacturer's signature (B. Darda, Chief Executive)

Applied EC Directive

- EC "Machinery" Directive 98/37/EEC (revised version of the directive 89/392/EEC including all alterations)

1.8 Symbols



DANGER!

Text that is marked with DANGER provides a warning about exceptionally large, immediate hazards which would, with certainty, result in serious or even fatal injuries if accident prevention measures are not taken. It is essential that you heed this text.



WARNING!

Text that is marked with WARNING provides a warning about exceptionally large, possible hazards which would, with certainty, result in serious or even fatal injuries if accident prevention measures are not taken. It is essential that you heed this text.



CAUTION!

Text which is marked with CAUTION provides a warning about a potentially dangerous situation which could result in minor injury or damage to property. It is essential that you heed this text.



Text that is marked with this symbol contains very important information, which may also include information for the prevention of health hazards. It is essential that you heed this text.



Text that is marked with this symbol contains important information, which may also include information for the prevention of material damage. It is essential that you heed this text.



This symbol indicates text which contains important information / comments or tips.



This dot marks the descriptions of activities that you should carry out.



This dash marks specifications.



This arrow marks a cross-reference.

If a cross-reference to another chapter is necessary in the text, this is shortened for clarity.

Example: **(⇨ 2 Safety Instructions)**

This means: see Chapter 2 Safety Instructions.

If the cross-reference refers to a page, figure or position number this information is added to the end of the cross-reference.



Numbers in brackets refer to the positions in figures.

2 Safety Instructions

Type C splitting cylinders are quality products manufactured based on recognised technological standards and were in a perfect condition in terms of safety and security when they were despatched from the factory.

The splitting cylinders conform to the currently valid safety norms and correspond to the guidelines laid down by the European Union.

(⇒ 1.7 Declaration of Conformity)

The splitting cylinders are safe when used correctly and in accordance with the descriptions and safety instructions included in this manual.



Nevertheless, there are dangers associated with the use of the splitting cylinders.

For this reason we explicitly and specifically advise all operators, that all personnel who will be commissioning, operating, adjusting and maintaining the splitting cylinders should be trained using this manual, with particular reference to the safety instructions contained in Chapter 2, before starting work with the splitting cylinders.

2.1 Responsibilities

2.1.1 Responsibility of the Operator

The operator is obliged to ensure that only personnel who satisfy the following conditions are allowed to work with the splitting cylinders:

- They shall be aware of the basic requirements of safe working practices and shall have been trained by qualified trainers in the use of the splitting cylinders and the hydraulic power unit.
- They shall have read and understood the safety and warning advice contained in this manual.
- They shall have received sufficient training in the work that is to be carried out.
- They shall be protected during their work by suitable personal safety equipment.

2.1.2 Responsibility of the Personnel

All personnel who are authorised to work with the splitting cylinders are obliged to:

- take the basic requirements of safe working practices and accident prevention into account,
- read the safety and warning advice contained in this manual and in the case of any uncertainties about what is meant, seek advice from an appropriate source,
- wear suitable personal safety equipment while working,
- stop work immediately if there are any safety issues and inform the responsible authority without delay.

2.2 Intended Use

Darda Type C splitting cylinders are designed for the splitting of concrete and natural stone. All other materials, e.g. metal, cannot be handled using this method.

When used in accordance with the corresponding environmental guidelines, the splitting cylinders can also be used under water.

No external mechanical forces should be applied to the splitting cylinder, in particular to the counter wedges and wedge, because of the danger of distortion.

Only the hydraulic oil specified in the Technical Data chapter should be used.

Only Darda hydraulic power units should be used, in order to ensure functional security and to abide by the terms of the guarantee.



Any further usage exceeding the specified ones will be considered as improper. The manufacturer cannot be held liable for any personal or material damage resulting thereby.

2.3 Structural Alterations / Repairs

- No structural modifications or changes may be made to the component and/or sub-assembly settings of the splitting cylinders and/or hydraulic power units.
- Repairs should only be carried out to the splitting cylinders and/or hydraulic power units either by the manufacturer or by specialists with good knowledge of hydraulics and mechanics.
- Only use the original replacement parts from the manufacturer for repairs.
- Repairs that have been carried out arbitrarily or without using the original replacement parts from the manufacturer may be detrimental to operational and functional safety.

2.4 Personal safety

2.4.1 Danger from toppling or falling material.



When demolishing buildings and natural stone, there is always the possibility of serious and unforeseen risks, which can only be combated by systematic planning, safety-conscious working practices and the application of experience.

There is always the danger that personnel located in the potential area of danger will suffer serious injuries such as loss of limbs, cuts, bruises or fractures by falling or toppling splitting cylinders or rocks.

- *Ensure that there is no danger occasioned to persons or to the environment through the commissioning or use of splitting cylinders and/or hydraulic power units.*
- *Take steps to ensure that during commissioning or use, no further persons are in the danger area of the splitting cylinders and/or hydraulic power units or can enter into the danger area.*
- *If required, set up warning notices to advise that the splitting cylinders are being commissioned or used.*
- *Plan how the work should be carried out before starting work and carry these plans out methodically. If required, seek information or advice from experts.*
- *Wear suitable personal safety equipment at all times, e.g. hard hat, protective clothing, safety boots, etc.*

2.4.2 Danger from mechanical movement of the splitting cylinder



If counter wedges or enlarging counter wedges should break off as a result of insufficient surface lubrication or through material fatigue, there is a danger of serious injuries such as bruising or fractures, caused by a sharp reverse movement of the splitting cylinder.



The compensating forces caused by a counter wedge breaking off normally leads to a sideways swing of the handle of some 10° or 20°. In the very rare case of both counter wedges breaking at the same time, it can happen that the splitting cylinder will move in an axial direction, i.e. out of the bore hole.

- *Before starting each splitting process, check that the pressure surfaces of the splitting wedge and the counter wedges have been sufficiently lubricated. The pressure surfaces should be lubricated at least every 3 or 5 times the device is used. You should only use the special Darda lubricant for this purpose.*
- *While splitting is in progress, always keep at least an arm's length from the splitting cylinder. Never hold on to the splitting cylinders (extended) direct axis while splitting is in progress.*

(↪ 5.2 Safety-conscious working practices)

- *Wear suitable personal safety equipment at all times, e.g. hard hat, protective clothing, safety boots, etc.*



WARNING!

2.4.3 Danger from machinery parts, which are under pressure

Escaping pressurised hydraulic oil can penetrate the skin causing poisoning, infection and serious injury to the eyes and other organs.

- *Make sure of correct connections when connecting hydraulic hoses (high pressure = smaller internal diameter; low pressure = larger internal diameter)*
- *Check the condition of hydraulic hoses, connections and all other hydraulic splitting cylinder components regularly.*
In the case of damage or if they are worn out, get them changed immediately by experts with a good knowledge of hydraulics and mechanics.
Please note that hydraulic hoses must be exchanged at the latest 6 years after the date of manufacture. This date can be found on the rubber coating of the hoses.
- *Make sure that all hydraulic machine parts have been depressurised before starting work on them.*
- *Please note that even when the hydraulic source has been deactivated, there is a danger that hydraulic oil is still located in the hydraulic pipes and that it may still be under pressure.*
- *When working on hydraulic hoses and/or machine parts, always wear suitable personal safety equipment at all times, e.g. hard hat, facial protection, protective clothing, etc.*

2.4.4 Danger from hot machine parts

After running the equipment for only a short time and even after a longer break in operations, hydraulic hoses or other machine parts can still be hot.

These can lead to severe burning if skin contact is made.

- *Please note that in normal use, hydraulic oil can reach temperatures of up to 80°C.*
- *Before working on hydraulic machine parts check that they are at a temperature where you can work without causing any danger to yourself.*
- *If necessary, make sure that there has been sufficient time for the hydraulic oil to cool down before starting work on hydraulic machine parts and/or splitting cylinders.*
- *Under no circumstances should you open the threaded joints of hydraulic machine parts that are still hot or are still under high pressure.*
- *Always position the operating lever of at least one splitting cylinder in the neutral position during longer interruptions with a running hydraulic power unit, because of the danger of the overheating of the hydraulic oil.*



CAUTION!



2.5 Machine protection

In order to protect the splitting cylinder from damage, please take note of the following advice and instructions.

-
- *Before starting each splitting process, check that the pressure surfaces of the splitting wedge and the counter wedges have been sufficiently lubricated. The pressure surfaces should be lubricated at least every 3 or 5 times the device is used. You should only use the special Darda lubricant for this purpose.*
 - *Avoid regular overloading of the splitting cylinder by using several splitting cylinders with the smallest possible bore hole spacing. Continuous reaching of maximum pressure and then the withdrawal of the splitting wedge without achieving splitting will lead to premature fatigue of the wedge sets and in some cases, to a shearing off of the wedge head. This is particularly liable to happen in the case of insufficient lubrication.*
 - *At or after each splitting process, check that the splitting wedge performs the correct movement after the operating lever is operated. If the splitting cylinder is used after the wedge head has broken off, this usually leads to the destruction of the splitting cylinder through an uncontrolled collision between the piston rod and the wedge.*
-

- *Always check that the splitting cylinder is safe to use before starting it up.*
- *Under no circumstances should you increase the pressure in the hydraulics. The pressure limiting valve in the hydraulic power unit must limit the hydraulic pressure to a maximum of 500 bar.*
- *Only use hydraulic oil released for use by the manufacturer.*
- *Never mix hydraulic oils with different viscosities or from different manufacturers. If in doubt, carry out a complete hydraulic oil change.*
- *Make sure of correct connections when connecting hydraulic hoses (high pressure = smaller internal diameter; low pressure = larger internal diameter).*
- *Make sure that when hydraulic hoses are disassembled no foreign bodies such as stones, sand or water get into the hoses.*
- *In the case of a malfunction of the splitting cylinder, disable the hydraulic source immediately, secure it against being accidentally turned back on and inform the appropriate authorities of the breakdown.*
- *Protect the splitting cylinder from damage by only using it for the purpose intended. Under no circumstances should you use it to hammer, to push masonry down, to lever splits open or similar.*
- *Always position the operating lever of at least one splitting cylinder in the neutral position during longer interruptions with a running hydraulic power unit, because of the danger of the overheating of the hydraulic oil.*
- *Remove any salt deposits after using the splitting cylinder under water by submerging the unit in fresh water and brushing any such deposits off.*

3 Unit Description

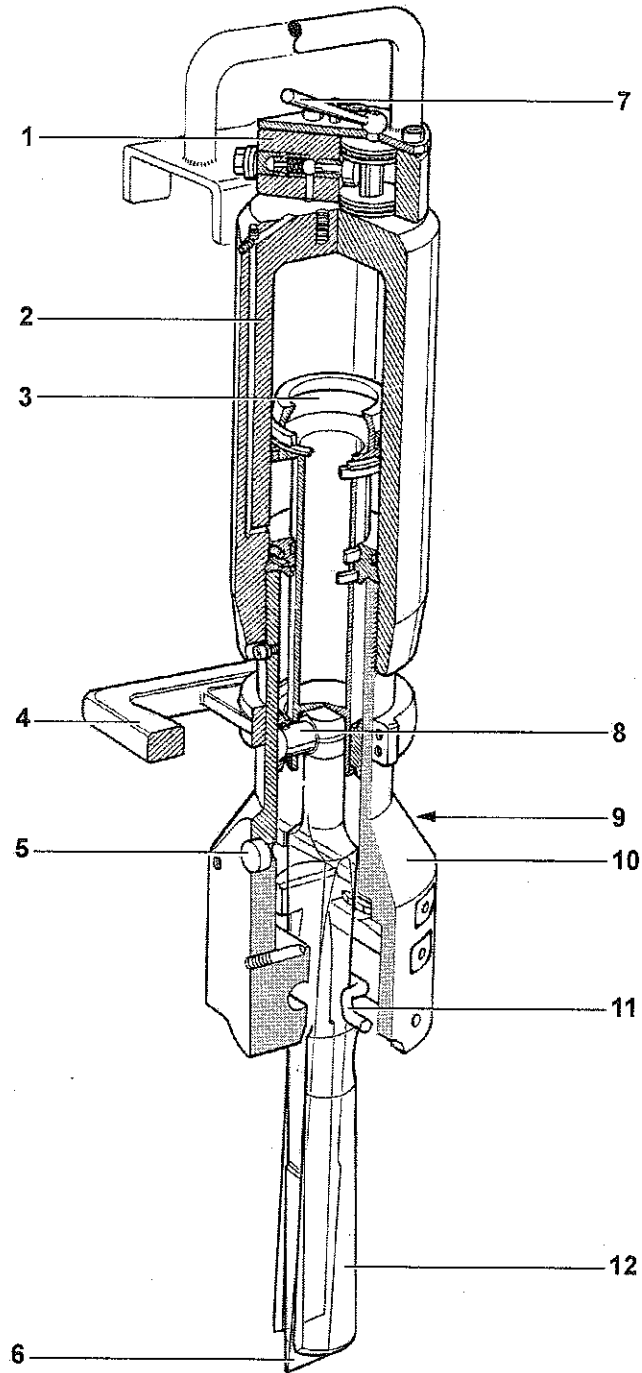

- | | |
|-------------------|--|
| 1 Control valve | 7 Operating lever |
| 2 Cylinder | 8 Bolts |
| 3 Piston rod | 9 Screw (on the other side of the plastic cap) |
| 4 Carrying handle | 10 Assembly body |
| 5 Plastic cap | 11 Hooks (1 right, 1 left) |
| 6 Splitting wedge | 12 Counter wedges (2 of) |

Fig. 3-1 Sectional drawing of a splitting cylinder

4 Work Planning

4.1 Drilling the bore holes

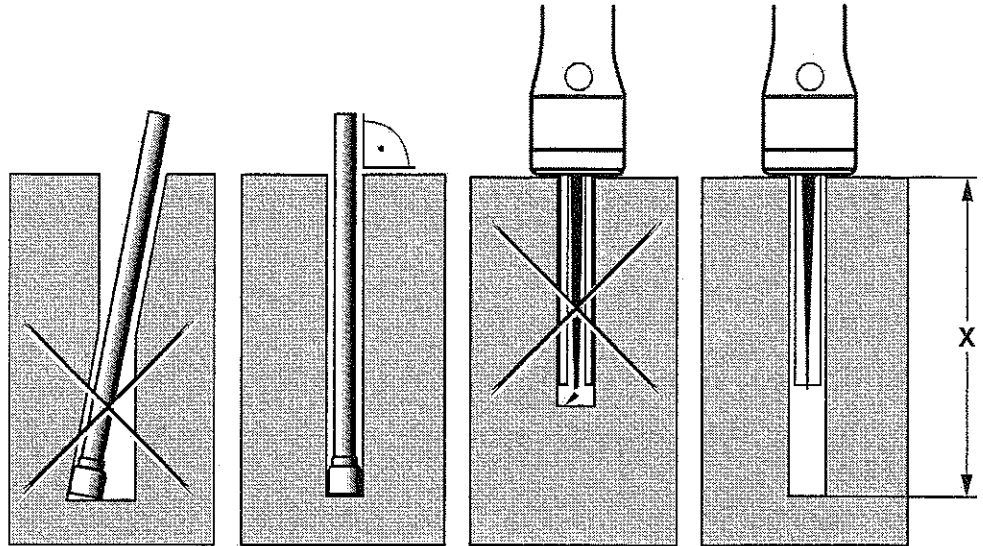

Fig. 4-1 Drilling the bore holes



In order to avoid damage to the splitting cylinder, the bore holes must be sized correctly and drilled very carefully.

Please note the following advice:

- To protect the wedge set, the bore hole must be as straight as possible.
- The bore hole diameter should not be greater than or less than the values quoted in the Technical Data chapter. Too much play between the wall of the hole and the wedge set reduces the effective splitting distance.
- The bore hole must be deeper than the length of the wedge set, when the wedge is completely extended.

(↔ 9 Technical data)

- Normally, the bore hole should be drilled vertically to the surface of the material.
- In order to create a long, straight split with several splitting cylinders, the gap between the bore holes should be between 40 and 60 cm.

The outside bore hole should be drilled about 60 cm from the edge.

If extremely accurate splitting is called for, e.g. when quarrying natural stone, test splits should be made with different drill spacings.

To control how the split is formed, intermediate bore holes can be drilled without using any splitting cylinders with them.

4.2 Connecting the hydraulic hoses

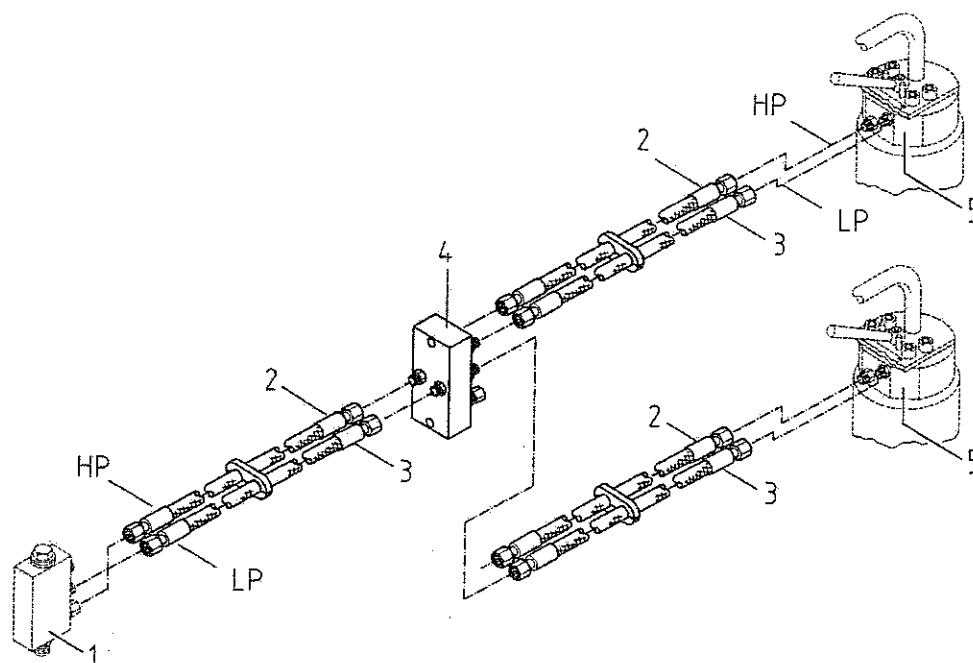

- 1 Pressure limiting valve on the hydraulic power unit
- 2 High-pressure hose
- 3 Low-pressure hose
- 4 Manifold
- 5 Control valve on the splitting cylinder

Fig. 4-2 Connecting the hydraulic hoses



WARNING!

When assembling the double hose sets, don't reverse the low and high pressure hoses. Don't kink the hoses and check for any damage before use. Damaged hose sets should not be used.

- **Before connecting the hydraulic hoses, please take note of the safety advice contained in Chapter 2 of this manual.**
(⇒ 2.4.3 Danger from machinery parts, which are under pressure)
- **Connect the splitting cylinder(s) to the hydraulic power unit, following the scheme shown in the above figure. Under no circumstances should the low and high pressure hoses be reversed.**

HP = High pressure = smaller internal diameter

LP = Low pressure = larger internal diameter

4.3 Lubrication

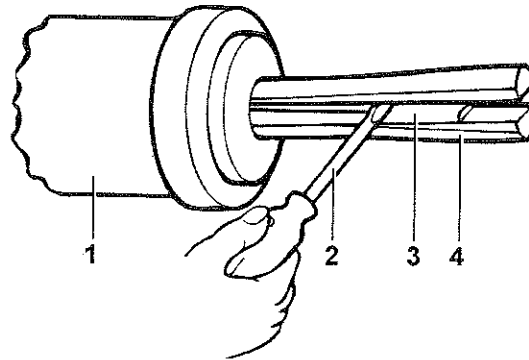

- 1 Splitting cylinder
- 2 Screw driver
- 3 Splitting wedge
- 4 Counter wedge

Fig. 4-3 Lubricating the counter wedges and the wedge



WARNING!

Insufficient surface lubrication or use of unsuitable lubricating agents can lead to a danger of serious injuries such as bruising or fractures, caused by a sharp reverse movement of the splitting cylinder.



Operating the splitting cylinder without or with insufficient lubrication usually leads to a cold-welding of the wedge set and possibly to a destruction of the splitting cylinder.

- **Before starting each splitting process, check that the pressure surfaces of the splitting wedge and the counter wedges have been sufficiently lubricated. The pressure surfaces should be lubricated at least every 3 or 5 times the device is used. You should only use the special Darda lubricant for this purpose.**
- Using a screwdriver or similar, spread the wedge set and using a spatula, for example, spread a thin layer of Darda special lubricating paste on the pressure surfaces of the counter wedges and the splitting wedge.



The advantages of the Darda special lubricating paste:

- Best results achieved during testing.
- Significant reduction in friction.
- Maximises the achievable splitting force (Splitting force with normal grease is 20% – 50% less).
- Reduced wear and need for replacement parts, which represents cost saving.
- Protects against corrosion.

5 Commissioning / Operation

5.1 Operation

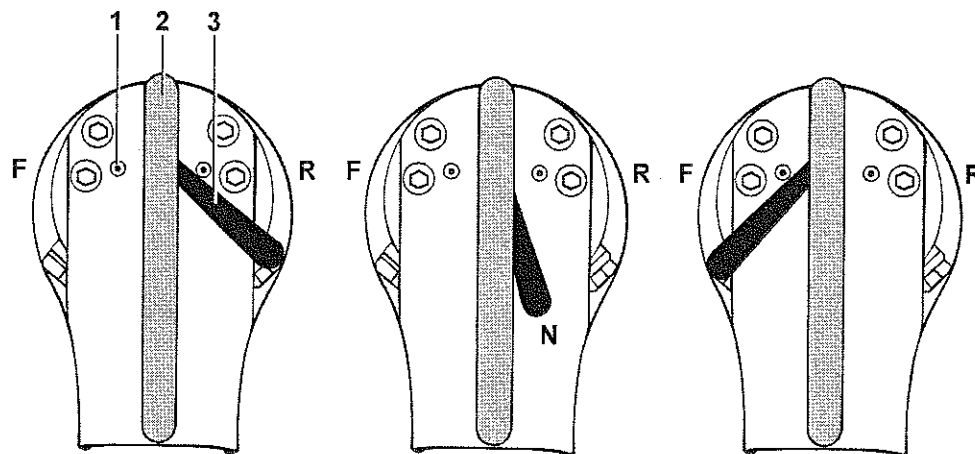

- 1 Fixing bolts
- 2 Handle
- 3 Operating lever

Fig. 5-1 Operating the splitting cylinder



WARNING!

- **Before starting work with the splitting cylinder, please take note of the safety instructions contained in Chapter 2 of this manual.**
(⇒ 2.4.2 Danger from mechanical movement of the splitting cylinder)

The splitting cylinder is operated using the operating lever, located at the head end of the device. There are three different operating conditions, depending on the position of the lever:

- R** Wedge is retracted
The wedge has been retracted. As soon as the wedge is fully retracted, the pressure limiting valve in the Darda unit removes pressure from the pressure cylinder. This is identified by a noticeable knock.
- N** Neutral position
The wedge remains stationary. The hydraulic equipment is not under pressure.
- F** Wedge is forward
The wedge is extended and pushes both counter wedges apart. As soon as the wedge is fully extended, the pressure limiting valve in the Darda unit removes pressure from the pressure cylinder. This is identified by a noticeable knock.



CAUTION!

Always position the operating lever of at least one splitting cylinder in the neutral position during longer interruptions with a running hydraulic power unit, because of the danger of the overheating of the hydraulic oil.

5.2 Safety-conscious working practices

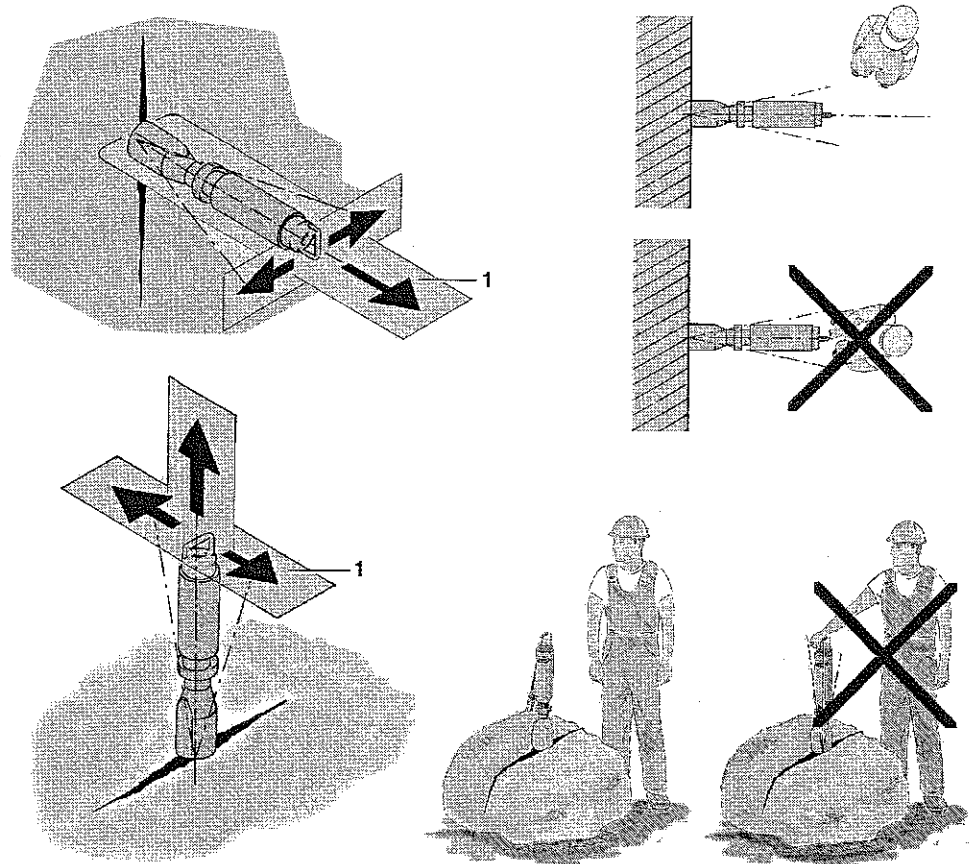

1 **Danger area**

When demolishing pressure bearing elements, there can be sudden and strong sideways or axial movements of the splitter.

Fig. 5-2 *Danger areas and correct operation*

- Feed the splitter by hand into the drilled hole as far as it will go (operating lever position: N / R ⇔ 5.1 operation)
- Turn the operating lever to position F.
- Let go of the splitter and for your own safety, move away a distance of at least 60 cm from the equipment.
- Never hold on to the splitting cylinders (extended) direct axis while splitting is in progress.
- When splitting is complete, turn the operating lever to position R. Wait until the wedge is fully inserted and you hear it strike the end.
- Now turn the operating lever to position N and pull the splitter out.

5.3 Enlarging

5.3.1 Type C2S & C4S splitting cylinders

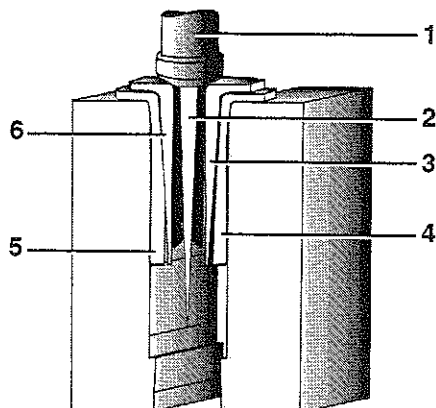

- 1 Splitting cylinder assembly body
- 2 Splitting wedge
- 3 Internal enlarging feather, 1st side
- 4 External enlarging feather, 1st side
- 5 External enlarging feather, 2nd side
- 6 Internal enlarging feather, 2nd side

Fig. 5-3 Enlarging, using enlarging feathers



After securing the split with a metal wedge, for example, the enlarging feather (4) is inserted completely into the split.

Then, you lay the second enlarging feather (3), which is thin at the bottom, flush with the assembly body (1) and push the wedge set together with enlarging feather (3) as far as possible into the split, with the splitting wedge in a retracted state.

Once the splitting wedge has been extended, secure the split again and repeat the process, until the enlarging feather (3) is also completely sunk into the split.

In order to achieve the maximum split distance, repeat the process using the second pair of enlarging feathers (5 & 6).

5.3.2 Type C9, C10S & C12 splitting cylinders
Enlarging with enlarging counter wedges

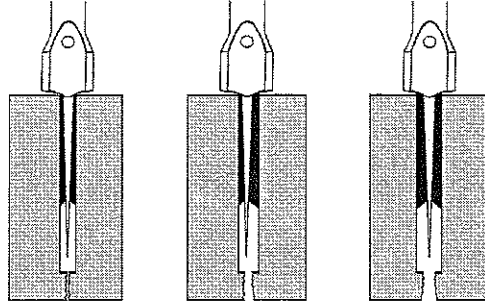

Fig. 5-4 Enlarging with enlarging counter wedges



To widen a split using these splitting cylinder types, the normal counter wedges are progressively replaced with thicker enlarging counter wedges. After each splitting and/or widening process, the split must be secured with a metal wedge, for example. Special enlarging counter wedges are available for types C9 and C12, for achieving particularly large split distances. For changing the counter wedges:

(⇒ 6.2.1 Changing the counter wedges)

Splitting with pressure shells

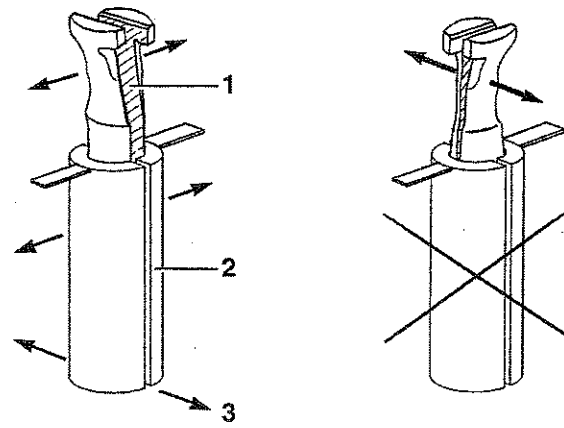

- 1 Counter wedge
- 2 Pressure shell
- 3 Direction of split

Fig. 5-5 Splitting with pressure shells



With strongly reinforced or bad quality concrete, the concrete around the bore hole can simply become compressed during splitting.

This problem can be solved by using two large surface pressure shells, which are available for the C9 and C12 types. A 100 mm bore hole must be drilled to use the pressure shells. Please take note of the data relating to bore hole depths in the Technical Data chapter.

Split enlarging can also be done using pressure shells and enlarging counter wedges.

6 Changing Wedge Sets

6.1 Type C4S splitting cylinders

6.1.1 Dismantling the splitting wedge and/or the counter wedges

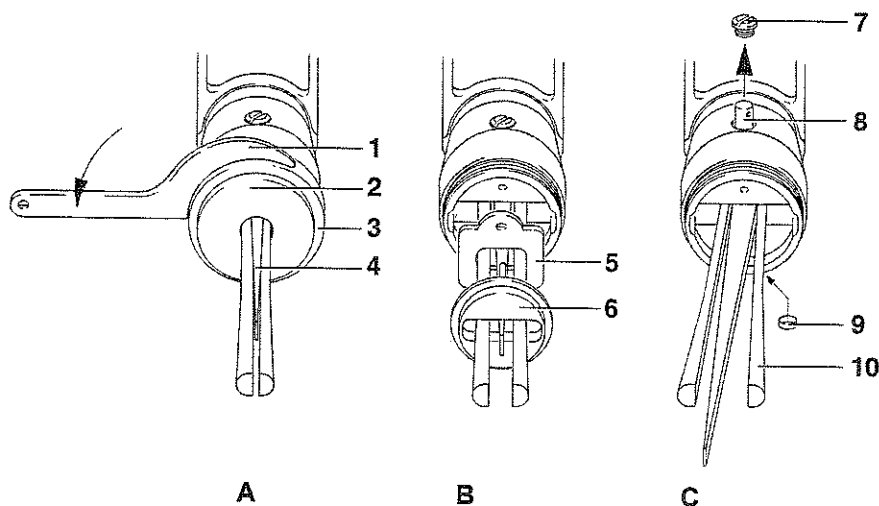

- | | |
|-------------------|------------------|
| 1 Hook wrench | 6 Guide disc |
| 2 Rubber washer | 7 Screw |
| 3 End cap | 8 Bolt |
| 4 Splitting wedge | 9 Plastic cap |
| 5 Rubber washer | 10 Counter wedge |

Fig. 6-1 Dismantling the splitting wedge and/or the counter wedges

- Fully retract the splitting wedge (4) (**Operating lever in position R**).
- Pull the rubber washer (2) off forwards.
- Remove the end cap (3) using the hook wrench (1) (Fig. A).
- Remove the guide disc (6) and the internal rubber washer (5) using a screwdriver (Fig. B).
- Fully extend the splitting wedge (**Operating lever in position F**).
- **Switch the hydraulic power unit off and secure it against being accidentally turned back on!**
- Remove the screw (7) and the plastic cap (9) on the other side.
- Knock the bolt (8) out of the head of the wedge using a hammer and spike (Fig. C).
- Pull the splitting wedge out of the splitting cylinder.
- If relevant, remove the counter wedges (10) by turning them through 90° and pulling them out.



6.1.2 Assembling the splitting wedge and/or the counter wedges

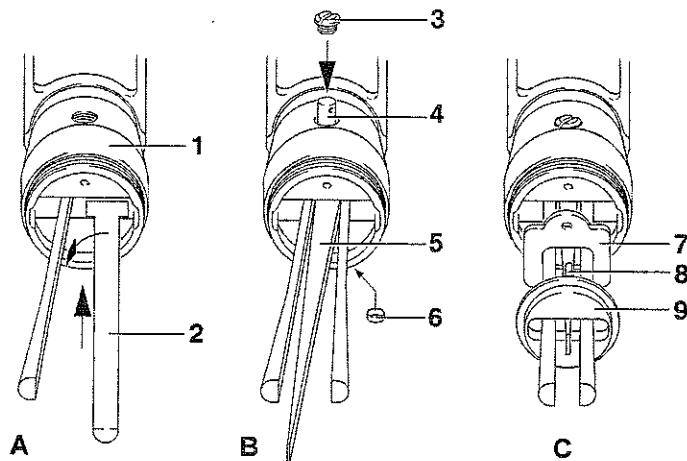

- | | |
|-------------------|-----------------|
| 1 Assembly body | 6 Plastic cap |
| 2 Counter wedge | 7 Rubber washer |
| 3 Screw | 8 Guide lug |
| 4 Bolt | 9 Guide disc |
| 5 Splitting wedge | |

Fig. 6-2 Assembling the splitting wedge and/or the counter wedges

- Insert the counter wedges (2) as required, by inserting them into the assembly body (1) and turning them through 90° (Fig. A).
- Spread the counter wedges and insert the counter wedge into the assembly body (1).
- Insert the bolt (4) through the screw opening in the splitting wedge bore and drive it carefully through the head of the wedge using a hammer and spike.



Operating the splitting wedge when the bolt is not completely inserted leads to damage to or destruction of the splitting cylinder!

- **Before starting up**, close the screw opening by screwing the screw (3) in **completely!**
- Insert the plastic cap (6) into the bore on the other side (Fig. B).
- Start-up the hydraulic power unit and retract the splitting wedge completely (**Operating lever in position R**).
- Press the rubber washer (7) into the recess in the assembly body.
- Insert the guide disc (9) with its guide lug (8) into the recess in the assembly body such that its surface is flush with the front of the assembly body (Fig. C).
- Screw the end cap (Fig. 6-1, Pos. 3) onto the assembly body using the hook wrench.
- Slide the rubber washer (Fig. 6-1, Pos. 2) over the splitting wedge on the front of the end cap.

6.2 Type C9, C10S, C12 splitting cylinders

6.2.1 Changing the counter wedges

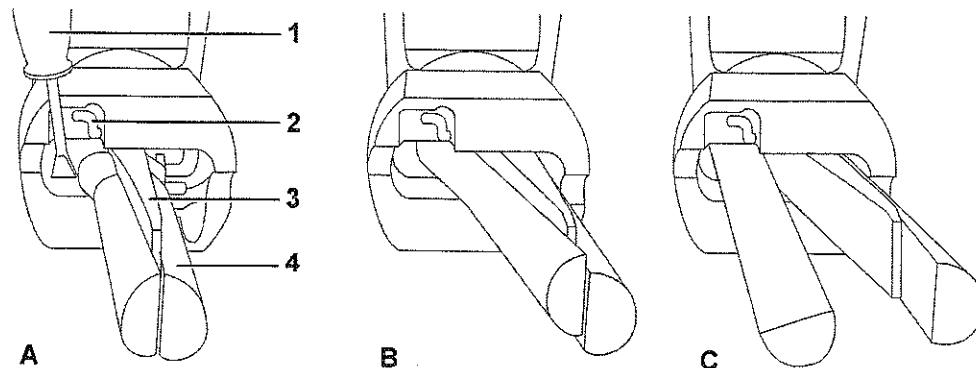

- 1 Screwdriver
- 2 Hooks (1 right, 1 left)
- 3 Splitting wedge
- 4 Counter wedge

Fig. 6-3 Changing the counter wedges

- Fully retract the splitting wedge (3) (**Operating lever in position R**).
- Using a screwdriver for example, push both hooks (2), up or down (Fig. A).
- Slide both counter wedges together with the splitting wedge on the right (Fig. B).
- Turn the left counter wedge through 90° and pull it out (Fig. C).
- Insert another counter wedge on the left-hand side or push the right-hand counter wedge, together with the splitting wedge to the left.
- Turn the right counter wedge through 90° and pull it out.
- Now change the splitting wedge as described on the next page or reassemble other counter wedges in the reverse order.

6.2.2 Changing the splitting wedge

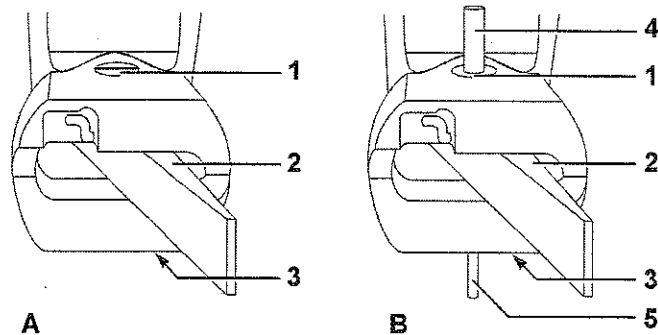

- | | |
|-----------------------------|-----------------------------------|
| 1 Screw | 4 Bolt |
| 2 Splitting wedge | 5 Spike for knocking the bolt out |
| 3 Plastic cap (not visible) | |

Fig. 6-4 Changing the splitting wedge



- Remove both counter wedges as described on the previous page.
- Fully extend the splitting wedge (2) (**Operating lever in position F**).
- **Switch the hydraulic power unit off and secure it against being accidentally turned back on!**
- Remove the screw (1) and the plastic cap (3) on the other side (Fig A).
- Knock the bolt (4) out of the head of the wedge using a hammer and spike (5) (Fig. B).
- Pull the splitting wedge out of the splitting cylinder.
- Assemble another splitting edge in the reverse order.

Operating the splitting wedge when the bolt is not completely inserted leads to damage to or destruction of the splitting cylinder!

- **Before starting up**, close the screw opening by screwing the screw (1) in **completely**.
- Assemble the counter wedges, as described in the previous chapter.

7 Shut-down

- Switch the hydraulic power unit off and secure it against being accidentally turned back on.
- Reduce the pressure in the hydraulics by moving the operating lever once or twice in its end position.

8 Error diagnostics

Crowder Supply Co., Inc. • 8495 Roslyn St., Commerce City, CO 80022 • Toll Free: 888-883-5144 • www.CrowderSupply.com

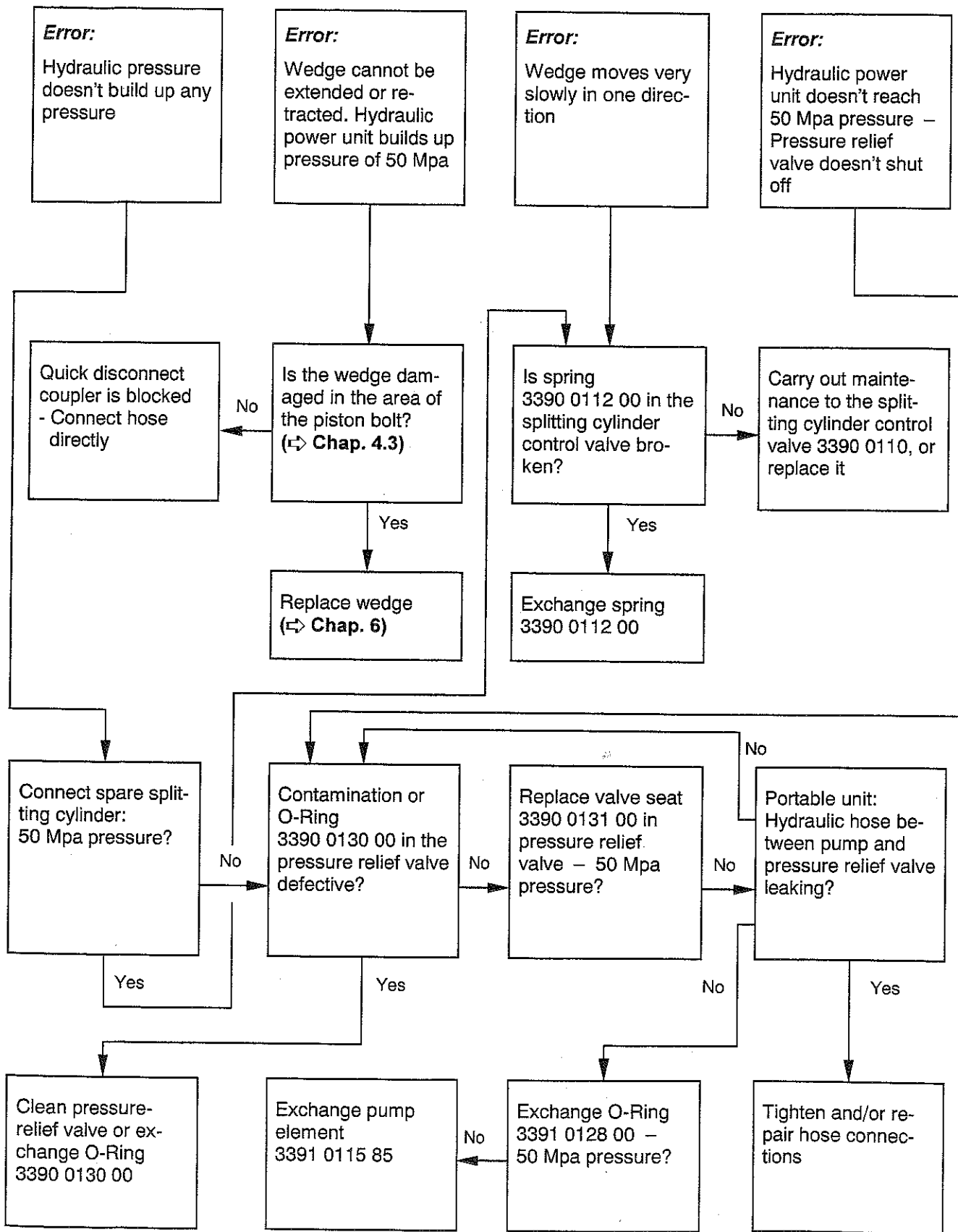

9 Technical Data

9.1 Splitting cylinders

Type	Wedge set	Required drill-hole diameter mm	Minimum drill-hole depth mm	Width of split mm	Theoretical splitting force kN/to
C2S	N	32-33	270	9	3490/355
C4S	N	35-36	430	10-40	4524/461
C4S	WL	35-38	540	14	3267/333
C4S	WLL	35-38	700	14	3267/333
C9	N	45-48	410	18-44	2995/305
C9	L	45-48	580	18-40	2995/305
C9	LL	48-50	1080	18-40	2995/305
C10S	N	41-43	630	18-45	4948/504
C12	W	45-48	550	24-56	4849/494
C12	N	45-48	610	20-50	6061/618
C12	L	45-48	680	15-35	8082/824

Type	Wedge set	Effective splitting force kN/to	Weight kg	Splitting cylinder length mm	Wedge set length mm
C2S	N	1913/195	18	745	140
C4S	N	2256/230	22	995	250
C4S	WL	1864/190	23	1145	400
C4S	WLL	1864/190	24	1255	510
C9	N	1962/200	22	1020	230
C9	L	1962/200	23	1190	400
C9	LL	1962/200	28	1690	900
C10S	N	2551/260	32	1400	380
C12	W	3150/321	31	1250	340
C12	N	3507/358	31	1290	380
C12	L	4048/413	32	1380	450

9.2 Hydraulic oil

Normal operating environment	Cold regions
ISO VG 22	ISO VG 10