



# VANAIR®

AIR POWER TO GO™

## Vanair ADHD Powertech 125 to 185 CFM Rotary Screw Air Compressor

### Installation, Operation, Maintenance and Parts List Manual

---

#### NOTE



Read this manual before installing, operating or servicing this equipment. Failure to comply with the operation and maintenance instructions in this manual WILL VOID THE EQUIPMENT WARRANTY.

**KEEP THE MANUAL  
WITH THE VEHICLE**

#### NOTE

Making unauthorized modifications to the compressor or system components **WILL VOID THE WARRANTY!**

Always inform Vanair Manufacturing, Inc., before beginning any changes to the ADHD system.

Vanair Manufacturing, Inc.

10896 West 300 North

Michigan City, IN 46360

Phone: (219) 879-5100

(800) 526-8817

Service Fax: (219) 879-5335

Parts Fax: (219) 879-5340

Sales Fax: (219) 879-5800

[www.vanair.com](http://www.vanair.com)

#### NOTE

Use only Genuine Vanair Parts. Inspect and replace damaged components before operation. Substituting non-Vanair components will **VOID THE COMPRESSOR WARRANTY!**



**VANAIR®**  
AIR POWER TO GO™

POO280-6

04/13

**WARRANTY** (Applies to following models: UDSM, UDISS, UDHD, ADHD, GENAIR, TMBD, ADBD)

---

The rotary screw compressor unit air end is warranted for life when adhering to the prescribed maintenance schedule. The unit will be replaced or repaired at VANAIR'S option. The hydraulic motor on the UDHD and ADHD is warranted for two (2) years. All other parts including the compressor unit shaft seal and generator are warranted for twelve (12) months. This warranty does not cover damage caused by accident, misuse or negligence. If a compressor unit is disassembled the warranty is void. Any disassembly of major components must be approved by Vanair to avoid voiding of warranty. Any and all such claims for warranty consideration must be coordinated through the Warranty-Service Department at the address below. Do **not** return parts without prior authorization.

Warranty is limited to the supply of replacement parts failing within the warranty period. Credit for labor required to refit replacement parts is NOT included. All warranted parts are to be shipped PREPAID to VANAIR. Replacement parts will be shipped back to the customer by VANAIR via ground shipment. Cost to expedite delivery of replacement parts will be incurred by customer. Factory installed units will also include warranty on the installation for one year.

Warranty will commence upon receipt of the Warranty Registration Card. If the Warranty Registration Card is not received within six (6) months, then warranty commencement date shall be thirty (30) days from the date of shipment from VANAIR. Records of warranty adherence are the responsibility of end user.

*This statement of warranty is expressly in lieu of and disclaims all other express warranties, implied warranties of merchantability and fitness for a particular purchase and all other implied warranties which extend beyond the description on the face hereof. The warranty does not include incidental or consequential damages.*

This warranty shall be void and VANAIR shall have no responsibility to repair, replace or repay the purchase price of defective or damaged parts resulting from the use of or repair of replacement parts or fluids not of VANAIR'S manufacture or from buyer's failure to store, install, maintain and operate the compressor according to the recommendations contained in the Manual.

All claims under the Warranty shall be made by contacting VANAIR Warranty-Service Department.



10896 West 300 North  
Michigan City, IN 46360  
Phone: (800) 526-8817 • (219) 879-5100  
Service Fax: (219) 879-5335 • Parts Fax: (219) 879-5340 • Sales Fax: (219) 879-5800

***TABLE OF CONTENTS***

<u><i>DESCRIPTION</i></u>	<u><i>SECTION</i></u>	<u><i>SECTION-PAGE NO.</i></u>
Warranty .....	-	Behind Cover
Table of Contents .....	-	<i>i</i>
Definition of Terms .....	-	<i>v</i>
<b><i>Section 1 – Safety</i></b> .....	<b><i>1.0</i></b> .....	<b><i>1-1</i></b>
General .....	1.1 .....	1-1
Parking or Locating Compressor .....	1.2 .....	1-2
Pressure Release .....	1.3 .....	1-2
Fire and Explosion .....	1.4 .....	1-3
Moving Parts .....	1.5 .....	1-5
Hot Surfaces, Sharp Edges, and Sharp Corners .....	1.6 .....	1-5
Toxic and Irritating Substances .....	1.7 .....	1-6
Electrical Shock .....	1.8 .....	1-7
Safety Decals .....	1.9 .....	1-7
<b><i>Section 2 – Description</i></b> .....	<b><i>2.0</i></b> .....	<b><i>2-1</i></b>
Introduction .....	2.1 .....	2-1
Sullair® Compressor Unit, Functional Description.....	2.2 .....	2-1
Compressor Cooling and Lubrication, Functional Description.....	2.3 .....	2-2
Compressor Discharge System, Functional Description.....	2.4 .....	2-2

*...Continued on next page*

# TABLE OF CONTENTS

<u>DESCRIPTION</u>	<u>SECTION</u>	<u>SECTION-PAGE NO.</u>
<b><i>Section 2 – Description (continued)</i></b>		
Control System, Functional Description.....	2.5.....	2-5
Air Inlet System, Functional Description .....	2.6.....	2-6
Instrument Panel, Functional Description.....	2.7.....	2-7
Hydraulic Motor, Functional Description.....	2.8.....	2-8
Electrical System, Functional Description.....	2.9.....	2-8
<b><i>Section 3 – Specifications .....</i></b>		
<b><i>3.0..... 3-1</i></b>		
Compressor Specifications.....	3.1.....	3-1
Lubrication Guide – Compressor.....	3.2.....	3-1
Application Guide.....	3.3.....	3-2
<b><i>Section 4 – Operation .....</i></b>		
<b><i>4.0..... 4-1</i></b>		
General .....	4.1.....	4-1
Purpose of Controls .....	4.2.....	4-1
Initial and Routine Start-Up Procedure s.....	4.3.....	4-2
<b><i>Section 5 – Installation .....</i></b>		
<b><i>5.0..... 5-1</i></b>		
Hydraulic System Requirements.....	5.1.....	5-1
Installation .....	5.2.....	5-1
Receiver Tank Installation.....	5.2.1.....	5-2
Wiring Diagram .....	5.3.....	5-3

*...Continued on next page*



# **TABLE OF CONTENTS**

<b><u>DESCRIPTION</u></b>	<b><u>SECTION</u></b>	<b><u>SECTION-PAGE NO.</u></b>
<b><i>Section 8 – Illustrations and Parts List</i></b> .....	<b>8.0</b> .....	<b>8-1</b>
Procedure for Ordering Parts .....	8.1 .....	8-1
Discharge System .....	8.2.....	8-2
Enclosure .....	8.3 .....	8-4
Instrument Panel .....	8.4.....	8-6
Inlet Valve Assembly .....	8.5.....	8-8
Oil Cooling System (electric) 125-185 CFM.....	8.6.....	8-10
Above Deck – Compressor, Air Inlet and Parts .....	8.7 .....	8-12
Above Deck – Hydraulic Drive .....	8.8.....	8-14
Decal Locations – 1 of 2 .....	8.9A.....	8-16
Decal Locations – 2 of 2 .....	8.9B.....	8-17
Installation/Test Record.....	-.....	8-19

**DEFINITION OF TERMS**

AD	Abovedeck
ABBD	Abovedeck Belt Drive
ADHD	Abovedeck Hydraulic Drive
ASME	American Society of Mechanical Engineers
BD	Belt Drive
CA	Cab to axle Length
CFM	Cubic Feet per Minute
EC	Electric Cooled
FC	Front Cooled
GAWR	Gross Axle Weight Rating
GPM	Gallons per Minute
GVWR	Gross Vehicle Weight Rating
HC	Hydraulic Cooled
HD	Hydraulic Drive
ICFM	Inlet Cubic Feet per Minute
PSI	Pounds per Square Inch
PSIG	Pounds per Square Inch Gauge
PTO	Power Take Off
RPM	Revolutions per Minute
SCFM	Standard Cubic Feet per Minute
SM	Side Mount
TM	Tractor Mount
TMBD	Tractor Mount Belt Drive
UD	Underdeck
UDHD	Underdeck Hydraulic Drive
UDISS	Underdeck Integral Split-Shaft
UDSM	Underdeck Side Mount
WB	Wheel Base

***BLANK PAGE***



# ***SECTION 1: SAFETY***

---

## **1.1 General**

Vanair<sup>®</sup> Manufacturing designs and manufactures all of its products so they can be operated **safely**. However, the responsibility for safe operation rests with those who use and maintain these products. The following safety precautions are offered as a guide which, if conscientiously followed, will minimize the possibility of accidents through the useful life of this equipment.

The air compressor should be operated only by those who have been trained and delegated to do so, and who have read and understood this Operator's Manual. Failure to follow the instructions, procedures and safety precautions in this manual can result in accidents and injuries.

**NEVER** start the air compressor unless it is safe to do so **DO NOT** attempt to operate the air compressor with a known unsafe condition. Tag the air compressor and render it inoperative by disconnecting the battery so others who may not know of the unsafe condition will not attempt to operate it until the condition is corrected.

Use and operate the air compressor only in full compliance with all pertinent OSHA requirements and/or all pertinent Federal, State and Local codes or requirements.

**DO NOT** modify the compressor except with written factory approval.

Each day walk around the air compressor and inspect for leaks, loose or missing parts, damaged parts or parts out of adjustment. Perform all recommended daily maintenance.

Inspect for torn, frayed, blistered or otherwise deteriorated and degraded hoses. Replace as required.

**NOTE:** Estimated hose life based on a 5-day 8-hour work week is 3 years. These conditions exist on an 8-hour shift only. Any other operation of the equipment other than 8-hour shifts would deteriorate the hose life based on hours of operation.

**1.2  Parking or Locating Compressor**

1. Park or locate compressor on a level surface, if possible. If not, park or locate compressor across grade so the compressor does not tend to roll downhill. **DO NOT** park or locate compressor on grades exceeding 15° (27%).
2. Make sure compressor is parked or located on a firm surface that can support its weight.
3. Park or locate compressor so the wind, if any, tends to carry the exhaust fumes and radiator heat away from the compressor air inlet openings, and also where the compressor will not be exposed to excessive dust from the work site.
4. Block or chock both sides of wheels.

**1.3  Pressure Release**

- A. Open the pressure relief valve at least weekly to make sure it is not blocked, closed, obstructed or otherwise disabled.
- B. Install an appropriate flow-limiting valve between the compressor service air outlet and the shutoff (throttle) valve, when an air hose exceeding 1/2" (13mm) inside diameter is to be connected to shut-off (throttle) valve, to reduce pressure in case of failure, per OSHA Standard 20 CFR 1926.302 (b) (7) or any applicable Federal, State and local codes, standards and regulations.
- C. When the hose is to be used to supply a manifold, install an additional appropriate flow limiting valve between the manifold and each air hose exceeding 1/2" (13mm) inside diameter that is to be connected to the manifold to reduce pressure in case of hose failure.
- D. Provide an appropriate flow-limiting valve for each additional 75 feet (23 meters) of hose in runs of air hose exceeding 1/2" (13mm) inside diameter to reduce pressure in case of hose failure.
- E. Flow-limiting valves are listed by pipe size and rated CFM. Select appropriate valve accordingly.
- F. **DO NOT** use tools that are rated below the maximum rating of this compressor. Select tools, air hoses, pipes, valves, filters and other fittings accordingly. **DO NOT** exceed manufacturer's rated safe operating pressures for these items.

**1.3**  **Pressure Release - *Continued***

- G. Secure all hose connections by wire, chain or other suitable retaining device to prevent tools or hose ends from being accidentally disconnected and expelled.
- H. Open fluid filler cap only when compressor **is not running and is not pressurized**. Shut down the compressor and bleed the sump (receiver) to zero internal pressure before removing the cap.
- I. Vent all internal pressure prior to opening any line, fitting, hose, valve, drain plug, connection or other component, such as filters and line oilers, and before attempting to refill optional air line anti-icer systems with antifreeze compound.
- J. Keep personnel out of line with and away from the discharge opening of hoses, tools or other points of compressed air discharge.
- K. **DO NOT** use air at pressures higher than 30 psig (2.1 bar) for cleaning purposes, and then only with effective chip guarding and personal protective equipment per OSHA Standard 29 CFR 1910.242 (b) or any applicable Federal, State and Local codes, standards and regulations.
- L. **DO NOT** engage in horseplay with air hoses as death or serious injury may result.
- M. This equipment is supplied with an ASME designed pressure vessel protected by an ASME rated relief valve. Lift the handle once a week to make sure the valve is functional. **DO NOT** lift the handle while machine is under pressure.
- N. If the machine is installed in an enclosed area it is necessary to vent the relief valve to the outside of the structure or to an area of non-exposure.
- O. If a manual blowdown valve is provided on the receiver, open the valve to insure all internal pressure has been vented prior to servicing any pressurized component of the compressor air/fluid system.

**1.4**  **Fire and Explosion**

- A. Refuel at a service station or from a fuel tank designed for its intended purpose. If this is not possible, ground the compressor to the dispenser prior to refueling.
- B. Clean up spills of fuel, fluid, battery electrolyte or coolant immediately if such spills occur.

**1.4**  **Fire and Explosion - Continued**

- C. Shut off air compressor and allow it to cool. Keep sparks, flames and other sources of ignition away. **DO NOT** permit smoking in the vicinity when adding fuel, checking or adding electrolyte to batteries, checking or adding fluid, checking diesel engine ether starting aid systems, replacing cylinders, or when refilling air line anti-icer systems antifreeze compound.
- D. **DO NOT** permit liquids, including air line anti-icer system antifreeze compound or fluid film to accumulate on bottom covers or on any external or internal surfaces of the air compressor. Wipe down using an aqueous industrial cleaner or steam clean as required. **DO NOT** use flammable solvents for cleaning purposes.
- E. Disconnect the grounded (negative) battery connection prior to attempting any repairs or cleaning inside the enclosure. Tag the battery connections so others will not unexpectedly reconnect it.
- F. Keep electrical wiring, including the battery terminals and other terminals, in good condition. Replace any wiring that has cracked, cut, abraded or otherwise degraded insulation, or terminals that are worn, discolored or corroded. Keep all terminals clean and tight.
- G. Turn off battery charger before making or breaking connections to the battery.
- H. Keep grounded conductive objects (such as tools) away from exposed live electrical parts (such as terminals) to avoid arcing, which might serve as a source of ignition.
- I. Keep a suitable fully charged class BC or ABC fire extinguisher or extinguishers nearby when servicing and operating the compressor.
- J. Keep oily rags, trash, leaves, litter or other combustibles out of and away from the compressor.
- K. **DO NOT** operate compressor under low overhanging leaves or permit such leaves to contact hot exhaust system surfaces when operating the compressor in forested areas.
- L. **DO NOT** spray ether into compressor air filter or into an air filter that serves the compressor as serious damage to the compressor or personal injury may result.
- M. Antifreeze compound used in air line anti-icer systems contains methanol which is flammable. Use systems and refill with compound only in well-ventilated areas away from heat, open flames or sparks. **DO NOT** expose any part of these systems or antifreeze compound to temperatures above 150°F (66°C). Vapors from the antifreeze compound are heavier than air. **DO NOT** store compound or discharge treated air in confined or unventilated areas. **DO NOT** store containers or antifreeze compound in direct sunlight.

**1.4**  **Fire and Explosion – Continued**

- N. Store flammable fluids and materials away from your work area. Know where fire extinguishers are and how to use them, and for what type of fire they are intended. Check readiness of fire suppression systems and detectors if so equipped.

**1.5**  **Moving Parts**

- A. Keep hands, arms and other parts of the body and also clothing away from belts, pulleys and other moving parts.
- B. **DO NOT** attempt to operate the compressor with the fan or other guards removed.
- C. Wear snug-fitting clothing and confine long hair when working around this compressor, especially when exposed to hot or moving parts inside the enclosure.
- D. Make sure all personnel are out of and clear of the compressor prior to attempting to start or operate it.
- E. Disconnect the grounded negative battery connection to prevent accidental engine operation prior to attempting repairs or adjustments. Tag the battery connection so others will not unexpectedly reconnect it.
- F. When adjusting the controls, it may require operation of the equipment during adjustment. **DO NOT** come in contact with any moving parts while adjusting the control regulator and setting the engine RPM. Make all other adjustments with the engine shut off. When necessary, make adjustment, other than setting control regulator and engine RPM, with the engine shut off. If necessary, start the engine and check adjustment. If adjustment is incorrect, shut engine off, readjust, then restart the engine to recheck adjustment.
- G. Keep hands, feet, floors, controls and walking surfaces clean and free of fluid, water, antifreeze or other liquids to minimize possibility of slips and falls.

**1.6**  **Hot Surfaces, Sharp Edges and Sharp Corners**

- A. Avoid bodily contact with hot fluid, hot coolant, hot surfaces and sharp edges and corners.
- B. Keep all parts of the body away from all points of air discharge and away from hot exhaust gases.
- C. Wear personal protective equipment including gloves and head covering when working in, on or around the compressor.

**1.6**  **Hot Surfaces, Sharp Edges and Sharp Corners – *Continued***

- D. Keep a first aid kit handy. Seek medical assistance promptly in case of injury. **DO NOT** ignore small cuts and burns as they may lead to infection.

**1.7**  **Toxic and Irritating Substances**

- A. **DO NOT** use air from this compressor for respiration (breathing) except in full compliance with OSHA Standards 29 CFR 1920 and any other Federal, State or Local codes or regulations.

**DANGER: Death or serious injury may occur from inhaling compressed air without using proper safety equipment. See OSHA standards, and/or any Federal, State or local codes or regulations on safety equipment.**

- B. **DO NOT** use air line anti-icer systems in air lines supplying respirators or other breathing air utilization equipment and **DO NOT** discharge air from these systems into unventilated or other confined areas.
- C. Operate the compressor only in open or well-ventilated areas.
- D. If the compressor is operated indoors, discharge engine exhaust fumes outdoors.
- E. Locate the compressor so that exhaust fumes are not apt to be carried towards personnel, air intakes servicing personnel areas or towards the air intake of any portable or stationary compressor.
- F. Fuels, fluids, coolants, lubricants and battery electrolyte used in the compressor are typical of the industry. Care should be taken to avoid accidental ingestion and/or skin contact. In the event of ingestion seek medical treatment promptly. **DO NOT** induce vomiting if fuel is ingested. Wash with soap and water in the event of skin contact.
- G. If ethyl ether or air line anti-icer system anti-freeze compound enters the eyes or if fumes irritate the eyes, they should be washed with large quantities of clean water for 15 minutes. A physician, preferably any eye specialist, should be contacted immediately.
- H. **DO NOT** store ether cylinders or air line anti-icer system antifreeze compound in operator's cabs or in other similar confined areas.
- I. The antifreeze compound used in air line anti-icer systems contains methanol and is toxic, harmful or fatal if swallowed. Avoid contact with the skin or eyes and avoid breathing the fumes. If swallowed, induce vomiting by administering a tablespoon of salt in each glass of clean warm water until vomit is clear, then administer two tablespoons of baking soda in a glass of clean water. Have patient lie down and cover eyes to exclude light. Call a physician immediately.

**1.8**  **Electrical Shock**

- A. Keep the vehicle or equipment carrier, compressor hoses, tools and all personnel at least 10 feet (3 meters) from power lines and buried cables.
- B. Keep all parts of the body and any hand-held tools or other conductive objects away from exposed live parts of electrical system. Maintain dry footing, stand on insulating surfaces and **DO NOT** contact any other portion of the compressor when making adjustments or repairs to exposed live parts of the electrical system.
- C. Attempt repairs only in clean, dry and well-lighted and ventilated areas.
- D. Stay clear of the compressor during electrical storms! It can attract lightning.

**1.9**  **Safety Decals**

Safety decals are placed onto, or located near, system components that can present a hazard to operators or service personnel. All pertinent decals listed in **Section 8.8, Decal Locations** are located near a component, which is subject to respect in terms of safety precautions.

- A. Always heed the information noted on the safety decals.

 **WARNING - DO NOT REMOVE OR COVER ANY SAFETY DECAL.**  
**Replace any safety decal that becomes damaged or illegible.**

***BLANK PAGE***



# ***SECTION 2: DESCRIPTION***

---

## **2.1 Introduction**

The Vanair<sup>®</sup> 85 through 185 Hydraulic Driven Air Compressors offer superior performance and reliability while requiring very minimal maintenance.

Your compressor is equipped with a Sullair rotary screw compressor unit. Compared to other compressors, the Sullair is unique for its mechanical reliability, performance and durability. The compressor never needs any inspection of the internal parts.

As you continue reading this manual and learn how the compressor operates and is maintained, you will see how surprisingly easy it is to keep a Vanair air compressor in top operating condition.

Read Section 6 (Maintenance) to keep your compressor in top operating condition. Should any problem or question arise which cannot be answered in this text, contact your nearest Vanair representative or the Vanair Manufacturing Service Department.

## **2.2 Sullair<sup>®</sup> Compressor Unit, Functional Description**

Vanair compressors feature the Sullair compressor unit, a single-stage, positive displacement, fluid lubricated-type compressor. This unit provides continuous pulse-free compression to meet your needs. With a Sullair compressor, no maintenance or inspection of the internal parts of the compressor unit is permitted in accordance with the warranty.

Fluid is injected into the compressor unit and mixes directly with the air as the rotors turn compressing the air. The fluid has three functions:

1. As coolant, it controls the rise of air temperature normally associated with the heat of compression.
2. Seals the leakage paths between the rotors and the stator and also between the rotors themselves.
3. Acts as a lubricating film between the rotors allowing one rotor to directly drive the other, which is an idler.

After the air/fluid mixture is discharged from the compressor unit, the fluid is separated from the air. At this time, the air flows to your service line and the fluid is cooled in preparation for re-injection.

### **2.3 Compressor Cooling and Lubrication System, Functional Description**

Refer to *Figure 2-1*. The compressor cooling and lubrication system is designed to provide adequate lubrication as well as maintain the proper operating temperature of the compressor. In addition to the cooler and fan, the system consists of an oil filter, electric fan switch.

The fluid in the system is used as both coolant and lubricant. It is housed in the receiver/sump or sump (which will be referred to as the SUMP from hereon).

The cooler is a radiator-type that works in conjunction with an electric driven fan and electric fan switch. The fan draws air across the cooler core removing the heat of compression from the fluid. The fluid flows from the sump thru the oil filter, thru the cooler core, and then is injected into the compressor chamber and bearings of the compressor. Once the oil reaches approximately 165°F the fan switch will turn on the fan to cool the oil.

The oil filter has a replaceable spin-on element and a built-in bypass valve which allows the fluid to flow even when the filter element becomes plugged and requires changing or when the viscosity of the fluid is too high for adequate flow. After the fluid is properly filtered, it then flows on to the compressor unit where it lubricates, seals and cools the compression chamber as well as lubricates the bearings and gears.

### **2.4 Compressor Discharge System, Functional Description**

Refer to *Figure 2-1*. The Sullair compressor unit discharges compressed air/fluid mixture. The air fluid mixture is directed to the combination sump. The sump has three functions:

1. It acts as a primary fluid separation system.
2. Serves as the compressor fluid sump.
3. Houses the air/fluid separator.

The compressed air/fluid mixture enters the sump and is directed off the bottom of the separator element. By change of direction and reduction of velocity, larger droplets of fluid separate and fall to the bottom of the sump. The fractional percentage of fluid remaining in the compressed air collects on the surface of the final separator element as the compressed air flows through the separator. As more and more fluid collects the element's surface, the fluid descends to the bottom of the separator. A return line (or scavenge tube) leads from the bottom of the separator element to the inlet region of the compressor unit. Fluid collecting on the bottom of the separator element is returned to the compressor by the pressure difference between the area surrounding the separator element and the compressor inlet. A filter orifice and sight glass assembly is included on this return line to help assure proper flow.

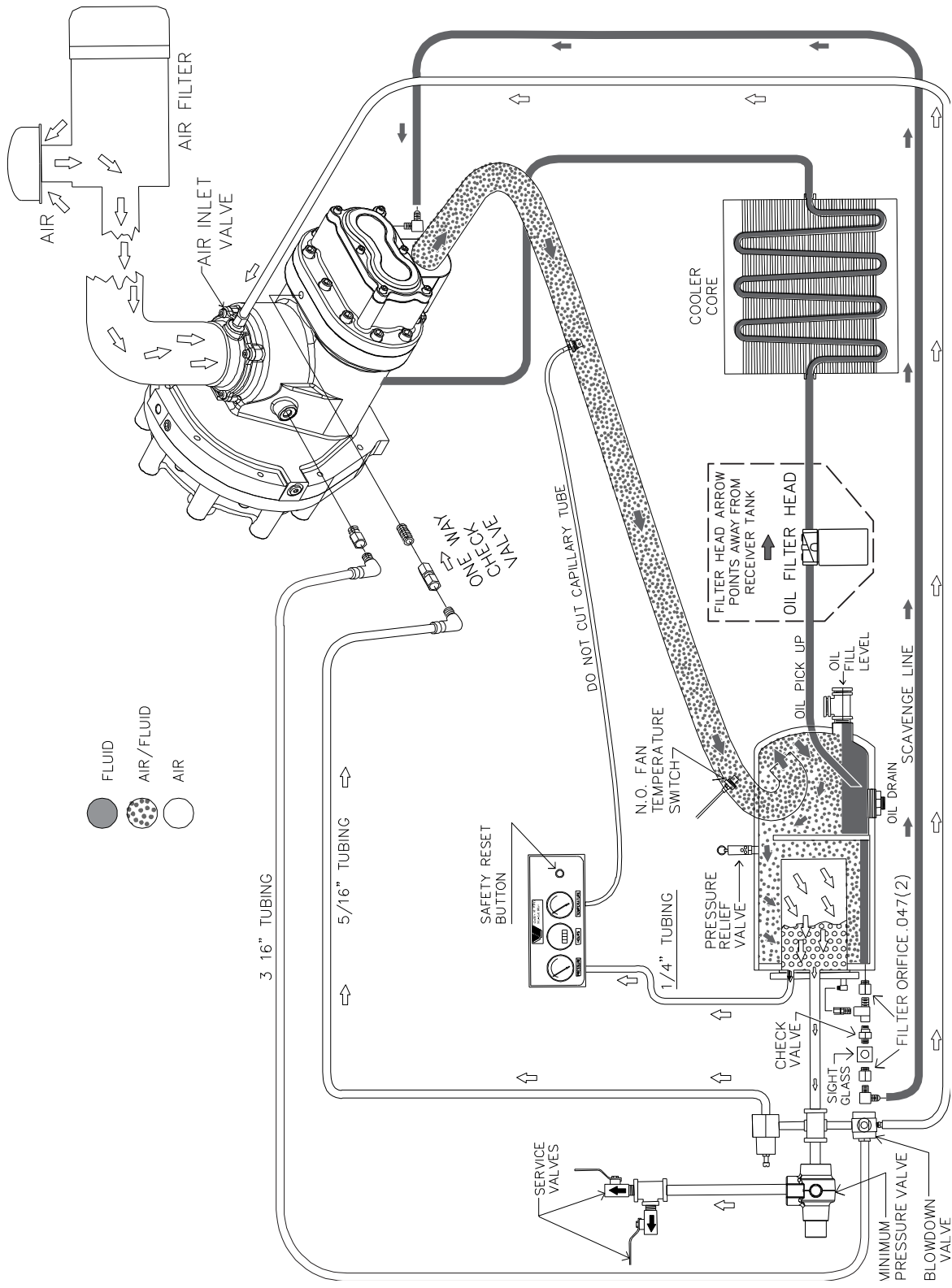

**Figure 2-1: Compressor Discharge and Cooling and Lubrication System**

**2.4 Compressor Discharge System, Functional Description - Continued**

The sump is ASME code rated at 175 psig working pressure. A minimum pressure/orifice valve, located downstream from the separator, helps assure a minimum receiver pressure of 65 psig during all conditions. This pressure is necessary for proper air/fluid separation and proper fluid circulation.

An optional check valve at the outlet of the receiver can be installed to prevent compressed air in the service line from bleeding back into the receiver on shutdown when the compressor is being run in parallel with other compressors tied to a large air system.

A pressure relief valve (located on the wet side of the separator) is set to open if the sump pressure exceeds 175 psig. A temperature switch will shut down the compressor if the discharge temperature reaches 240°F.

Fluid is added to the sump via a capped fluid fill port (*Figure 2-2*). A glass fluid level gauge enables the operator to visually monitor the sump fluid level.

**⚠ WARNING: DO NOT** remove caps, plugs, and/or other components when compressor is running or pressurized. Stop compressor and relieve all internal pressure before doing so.

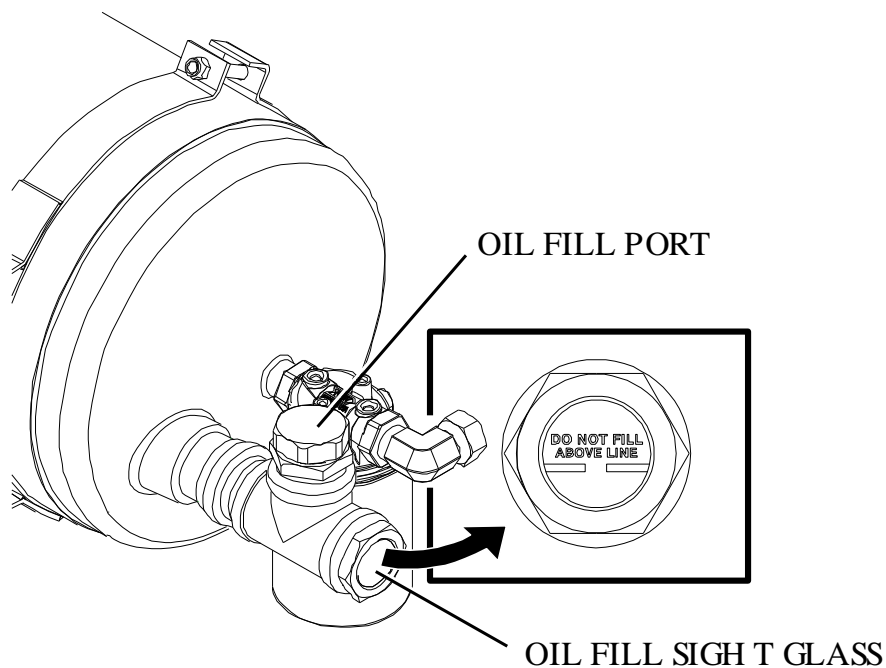

*Figure 2-2: Oil Fill Port and Sight Glass*

## **2.5 Control System, Functional Description**

Refer to *Figure 2-1*. The purpose of the control system is to regulate the amount of air intake in accordance with the amount of compressed air demand. The **Control System** consists of an **air inlet valve**, a **control regulator**, **blowdown valve**, and tubing connecting the various components together.

The functional descriptions of the Control System are given below in two distinct phases of operation. These descriptions will apply to all control systems.

### **Start - 0 to 40 PSIG**

The sump pressure will quickly rise from 0 to 40 psig. During this period the compressor inlet valve control chamber has received no air signal from the pressure regulator. The spring attached to the control plunger holds it in a wide open position allowing the compressor to work at full-rated capacity. As the compressor operates at full-rated capacity, the engine speed control remains fully open enabling the trucks engine to run at full speed. The rising sump pressure begins to pass air through the minimum pressure orifice.

### **Modulation - 100 to 115 PSIG**

Should less than the rated capacity of air be used, the service line pressure will rise above 100 psi. The control pressure regulator gradually opens, applying pressure to the spring side of the inlet valve piston. This causes the inlet valve to partially close. With the service line closed and no air demand, the control pressure regulator opens fully, closing the inlet valve.

When air demand then increases, the sump pressure will fall below 115 psig (7.9 bar). The control pressure regulator valve will close, and the inlet valve to open. The compressor will then be operating at full load condition.

### **Shutdown**

The blowdown valve is normally closed. When the compressor is shut down, system pressure backs up to the inlet valve causing the check spring in the inlet valve to close the air inlet valve. This sends a pressure signal to the blowdown valve causing it to open and vent the pressure in the system. After the pressure is vented, the blowdown valve spring returns the blowdown valve to the closed position.

## 2.6 Air Inlet System, Functional Description

Refer to *Figure 2-3*. The compressor inlet system consists of **one air filter**, a **compressor air inlet valve** and **interconnecting piping**.

The air filter is a two-stage, dry element-type filter. This filter is capable of cleaning extremely dirty air. However, in such cases, frequent checks of the air filter will be required. See **Section 6.5.2** for Air Filter Maintenance Procedures.

The compressor air inlet valve controls the amount of air intake of the compressor in response to the air demand.

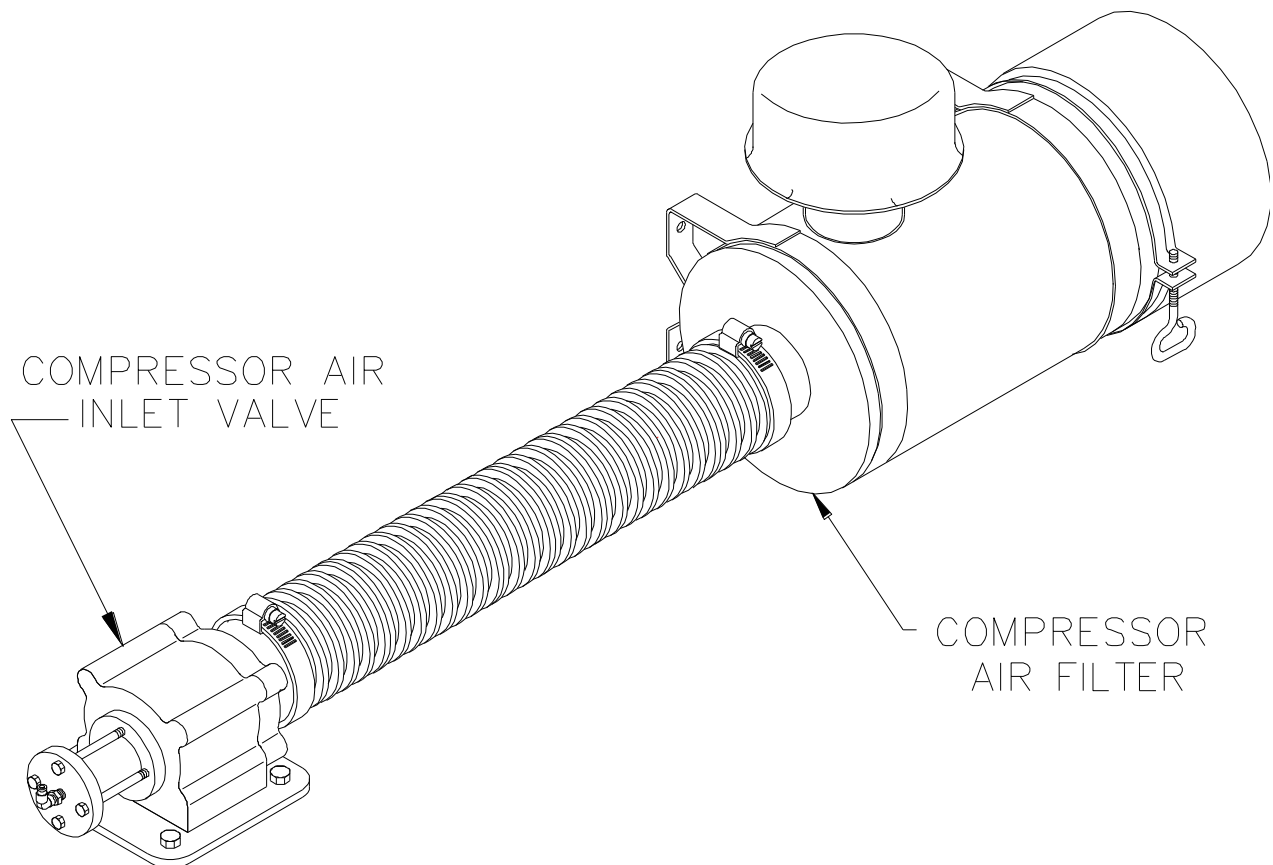

*Figure 2-3: Air Inlet System*

**2.7 Instrument Panel, Functional Description**

Refer to *Figure 2-4*. The instrument panel group consists of a receiver pressure gauge, an hour meter, a compressor discharge temperature gauge and reset button.

- The **air pressure gauge** continually monitors the sump pressure at various load and/or unload conditions.
- The **hour meter** indicates the cumulative hours of compressor operation which is useful for planning and logging service operations.
- The **compressor discharge temperature gauge** monitors the temperature of the air/fluid mixture leaving the compressor unit. The normal reading should be approximately 180°F to 210°F.
- The **reset button** cancels and/or resets over-pressure/over-temperature shut-down condition.

**!** **WARNING:** Never force the reset button back into position, or hinder it in any way, in order to allow for machine operation. A tripped reset button indicates a problem that should be addressed and resolved before operation can continue.

**NOTE:** When re-starting the compressor, make sure receiver tank pressure has blown down to 10 psig can put extra load on the hydraulic system.

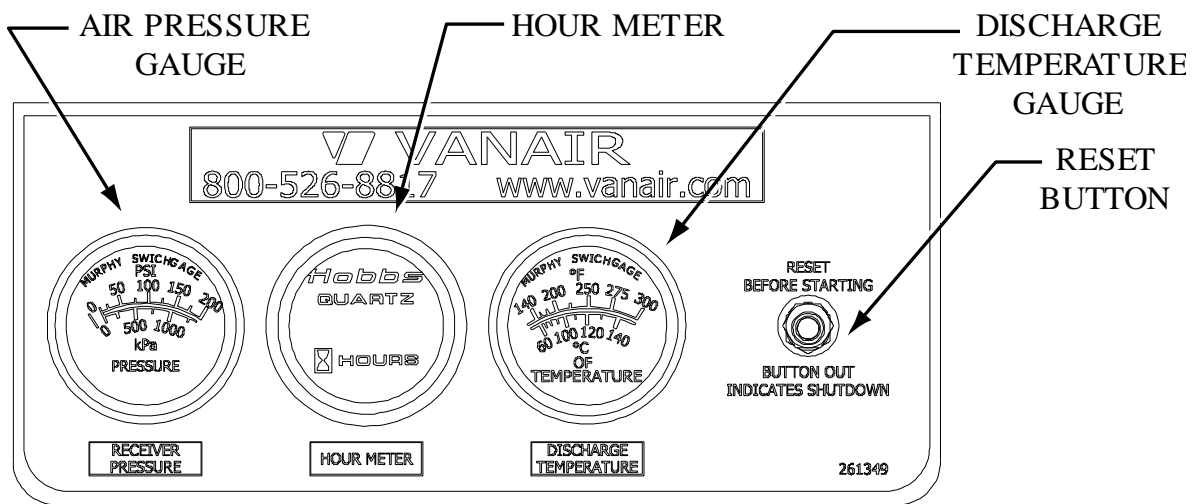

*Figure 2-4: Instrument Panel Group*

**2.8 Hydraulic Motor, Functional Description**

The hydraulic motor is used to power the compressor unit. If the proper flow and pressure is supplied to the motor there should be many hours of trouble free use in conjunction with the compressor.

Vanair<sup>®</sup> does not supply or recommend any other hydraulic system component information. It is recommended that the person installing a Vanair hydraulic driven compressor seek in their area a reputable hydraulic supplier for the hydraulic components (i.e: pump, relief valve, oil cooler, flow control, hosing, reservoir).

Following is a list of flows and pressures for the appropriate compressor model.

<b>C.F.M. Nominal</b>	<b>Air Pressure PSIG</b>	<b>Compressor Speed R.P.M.</b>	<b>H.P.</b>	<b>Min. Recom. System Pressure</b>	<b>Oil Flow G.P.M.</b>
85	100	1460	23.3	2300	20.5
85	150	1460	29.4	2700	20.5
125	100	1330	30.2	2200	26.4
125	150	1330	37.8	2700	26.4
160	100	1675	39.2	2300	33.5
160	150	1675	48.7	2700	33.5
185	100	1920	45.6	2400	38.5
185	150	1920	57.1	2900	38.5

**2.9 Electrical System, Functional Description**

The electrical system is comprised of not only the necessary equipment required to operate the compressor, but also a system to shut it down in the event of a malfunction. The components of the **electrical system** are a **compressor discharge temperature switch** (which will shut down the compressor should the compressor temperature exceed 240°F).



# ***SECTION 3: SPECIFICATIONS***

<b>3.1 Compressor Specifications</b>	
<b>Type:</b>	Rotary Screw
<b>Delivery @ Operating Pressure:</b>	85 Free CFM @ 100 psig
	85 Free CFM @ 150 psig
	125 Free CFM @ 100 psig
	125 Free CFM @ 150 psig
	160 Free CFM @ 100 psig
	160 Free CFM @ 150 psig
	185 Free CFM @ 100 psig
<b>Cooling:</b>	Pressurized Compressor Fluid
<b>Lubricating Compressor Fluid:</b>	(Factory Fill) Vanair <sup>®</sup> Vanguard <sup>™</sup> High Performance Rotary Screw Compressor Oil
<b>Sump Capacity:</b>	Three (3) U.S. Gallons (sump)
	3-1/2 U.S. Gallons (total system)

### **3.2 Lubrication Guide - Compressor**

**IMPORTANT** - The compressor oil must be of a recommended type, that is inspected and replaced together with the oil and air filters, in accordance with this manual.

**CAUTION – DO NOT MIX OILS OF DIFFERENT TYPES—** Substituting non-Vanguard Oil or non-genuine Vanair filter components **WILL VOID THE COMPRESSOR WARRANTY!**

The result of poorly maintained lubricant and/or filters may produce hazardous conditions resulting in ignition, which could cause a fire in the sump. Damage to equipment and serious bodily harm may result.

<b>PRIME LUBRICANT CHARACTERISTICS</b>	
Viscosity:	178 SUS at 100°F (38°C)
Flashpoint:	457° F (236°C)
Pour Point	-49°F (-45°C)
Contain:	Rust and Oxidation Inhibitors
Contain:	Detergents

**3.3 Application Guide**

Water must be drained from the receiver periodically. In high ambient temperature and high humidity conditions, condensed moisture may emulsify with the oil forming a “milky” color. The fluid should be changed if this condition develops.

**IMPORTANT** — **DO NOT** mix different types of fluids. Combinations of different fluids may lead to operational problems such as foaming, filter plugging, orifice or line plugging. Mixing different types of fluids will void the warranty.

# ***SECTION 4: OPERATION***

## **4.1 General**

While Vanair® has built into this compressor a comprehensive array of controls and indicators to assure you that it is operating properly, you will want to recognize and interpret the readings which will call for service or indicate the beginning of a malfunction. Before starting your Vanair compressor, read this section thoroughly and familiarize yourself with the controls and indicators - their purpose, location and use.

<b>4.2 Purpose of Controls</b>	
<b>CONTROL OR INDICATOR</b>	<b>PURPOSE</b>
AIR PRESSURE GAUGE	Continually monitors the pressure inside the receiver tank at various load and unload conditions.
HOUR METER	Indicates the cumulated hours of operation. Useful for planning and logging service schedules.
COMPRESSOR DISCHARGE TEMPERATURE GAUGE	Monitors the temperature of the air/fluid mixture leaving the compressor unit. The normal reading should be approximate 180° to 210°F.
FLUID LEVEL SIGHT GLASS	Monitors the fluid level in the sump. Proper level is always visible in the sight glass.  Check the level when the compressor is shut down.
COMPRESSOR DISCHARGE TEMPERATURE SWITCH	Opens the electrical circuit to shut down the compressor when the discharge temperature reaches 240°F.
INLET VALVE	Regulates the amount of air allowed to enter the air end. This regulation is determined by the amount of air being used at the service line.

<b>4.2 Purpose of Controls (Continued)</b>	
<b>CONTROL OR INDICATOR</b>	<b>PURPOSE</b>
MINIMUM PRESSURE ORIFICE	Maintains the minimum of 65 psig in the compressor sump. This valve restricts receiver air discharge from receiver/sump when pressure falls to 65 psig, however, full flow is allowed at normal operating pressures.
PRESSURE RELIEF VALVE	Opens sump pressure to the atmosphere should pressure inside the sump exceed 175 psig.
PRESSURE REGULATOR	Opens a pressure line between the sump and inlet valve allowing the inlet valve to regulate air delivery according to air demand.
SYSTEM BLOWDOWN VALVE	Vents sump pressure to the atmosphere at shutdown.

### **4.3 Initial and Routine Start-Up Procedures**

The following procedure should be used to make the initial start-up of your compressor:

1. Position the compressor on a level surface so that proper amounts of liquid can be added if necessary.
2. Fill compressor fluid sump with fluid as recommended in **Section 3, Specifications**. System capacity is 3-1/2 gallons.
3. Check engine oil level and add if necessary.
4. Start truck engine (let engine warm up).
5. Engage hydraulic system.
6. Bring up engine speed to proper RPM.
7. After the initial run, shut the compressor down and refill compressor with oil and tighten any loose fittings.

For routine start-up of compressor system repeat steps #3 through #6.

---

# ***SECTION 5: INSTALLATION***

---

## **5.1 Hydraulic System Requirements**

**IMPORTANT** - Vanair® highly recommends consulting a hydraulic supply expert for specifying the correct hydraulic pump size and type, oil reservoir size, hydraulic cooler, hydraulic pressure relief, and other hydraulic supply components for your application.

Please take into consideration the following:

- The hydraulic flow and pressure requirements of the air compressor.
- Keep in mind that when the compressor is running there is a continuous hydraulic load.
- The duty cycle and ambient operating temperatures.
- Other hydraulic equipment which may share that same hydraulic supply system (Vanair recommends a dedicated pump and hydraulic circuit).

**NOTE** – The temperature of the hydraulic oil should not exceed 140°F due to the rating of the Vanair supplied hydraulic motor.

## **5.2 Installation**

Refer to **Section 5.4** for dimensions. A location on the truck is the first thing that needs to be determined. Some of the concerns that need to be taken into consideration include:

- There must be enough room around the compressor package to insure proper cooling.
- There must be enough room to service the air cleaner, separator element, and oil filter.
- The instrument panel should be readily seen without obstruction for daily operations.

Once a location is found, the compressor package should be mounted down with a minimum of (4) 1/2-13 capscrews.

The hydraulic hoses must be run into the package to the hydraulic motor. Insure the hoses are hooked up properly to insure proper rotation. Also, insure that the hoses are run through an area so that no chafing of the hoses is possible.

The hydraulic compressor package should be wired per wire diagram (**Section 5.3**). There are a total of (4) wires to be run inside of the package.

## 5.2.1 RECEIVER TANK INSTALLATION

1. Always install tank with drain plug at bottom.
2. Do not install tank above height of compressor.

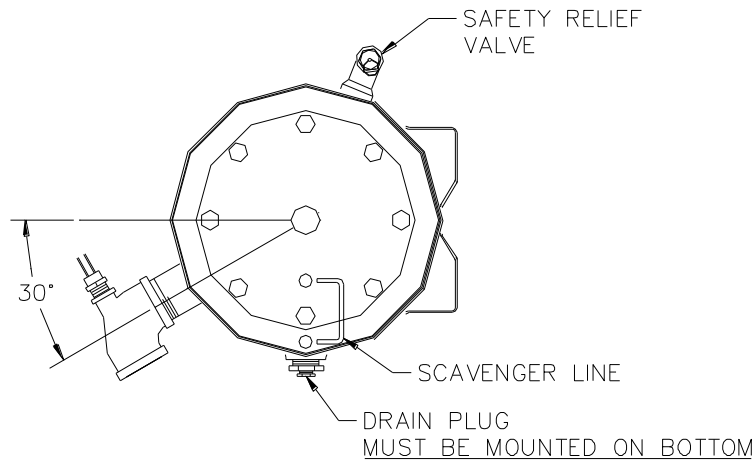

12" DIA. IN-TANK SEPARATOR SYSTEM  
125/160/185 CFM  
VIEWED FROM FLAT END

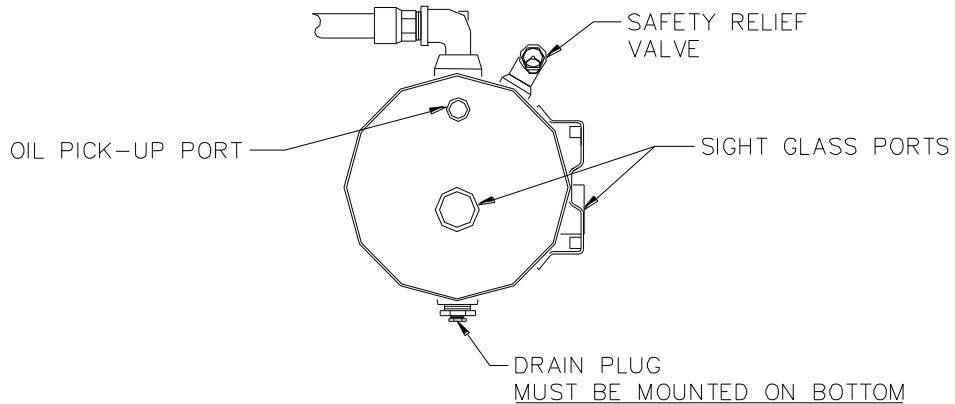

10" DIA. SPIN-ON SEPARATOR SYSTEM  
60/85 CFM  
VIEWED FROM OIL FILTER END

## 5.3 Wire Diagram

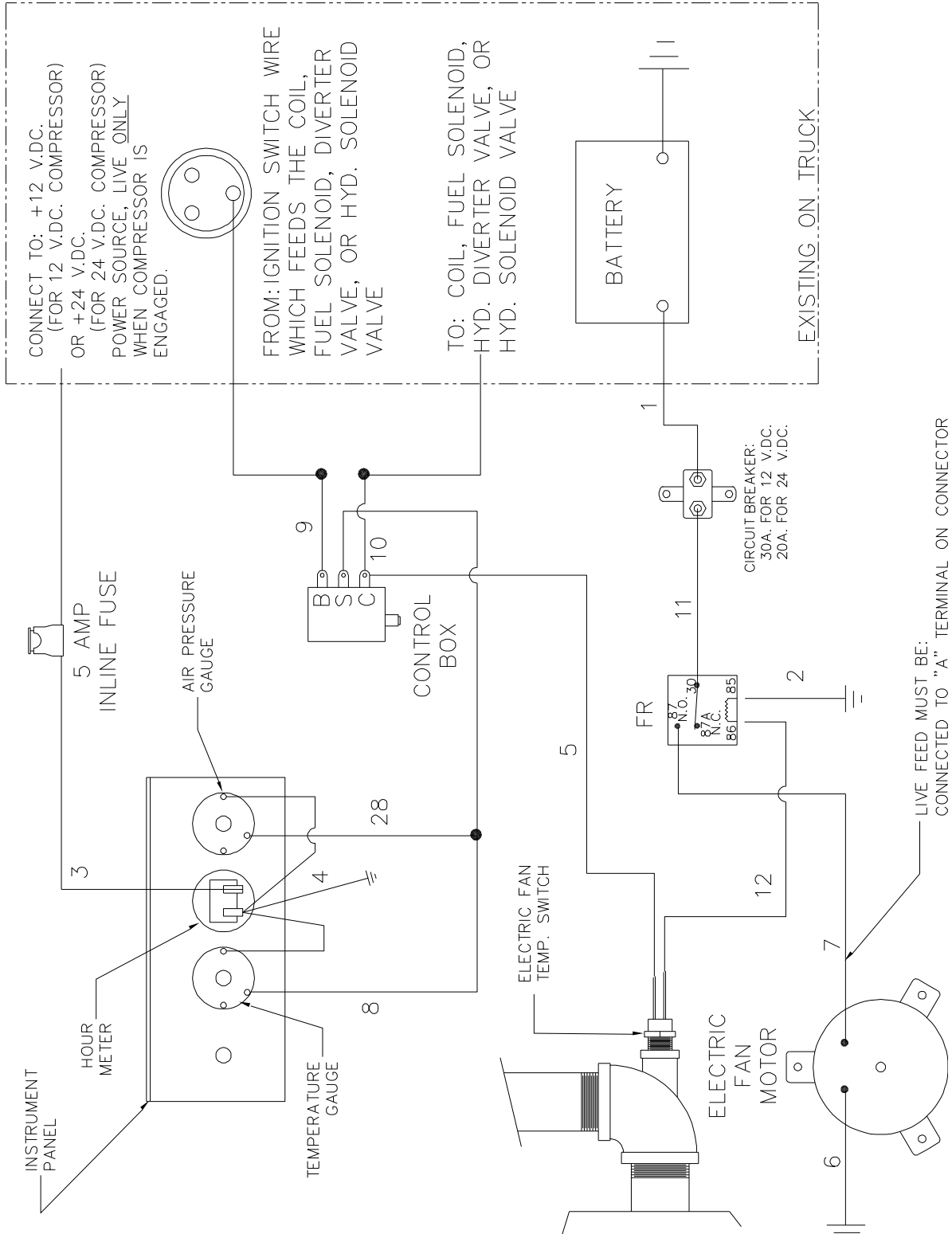

**5.4 Dimensions Diagram**

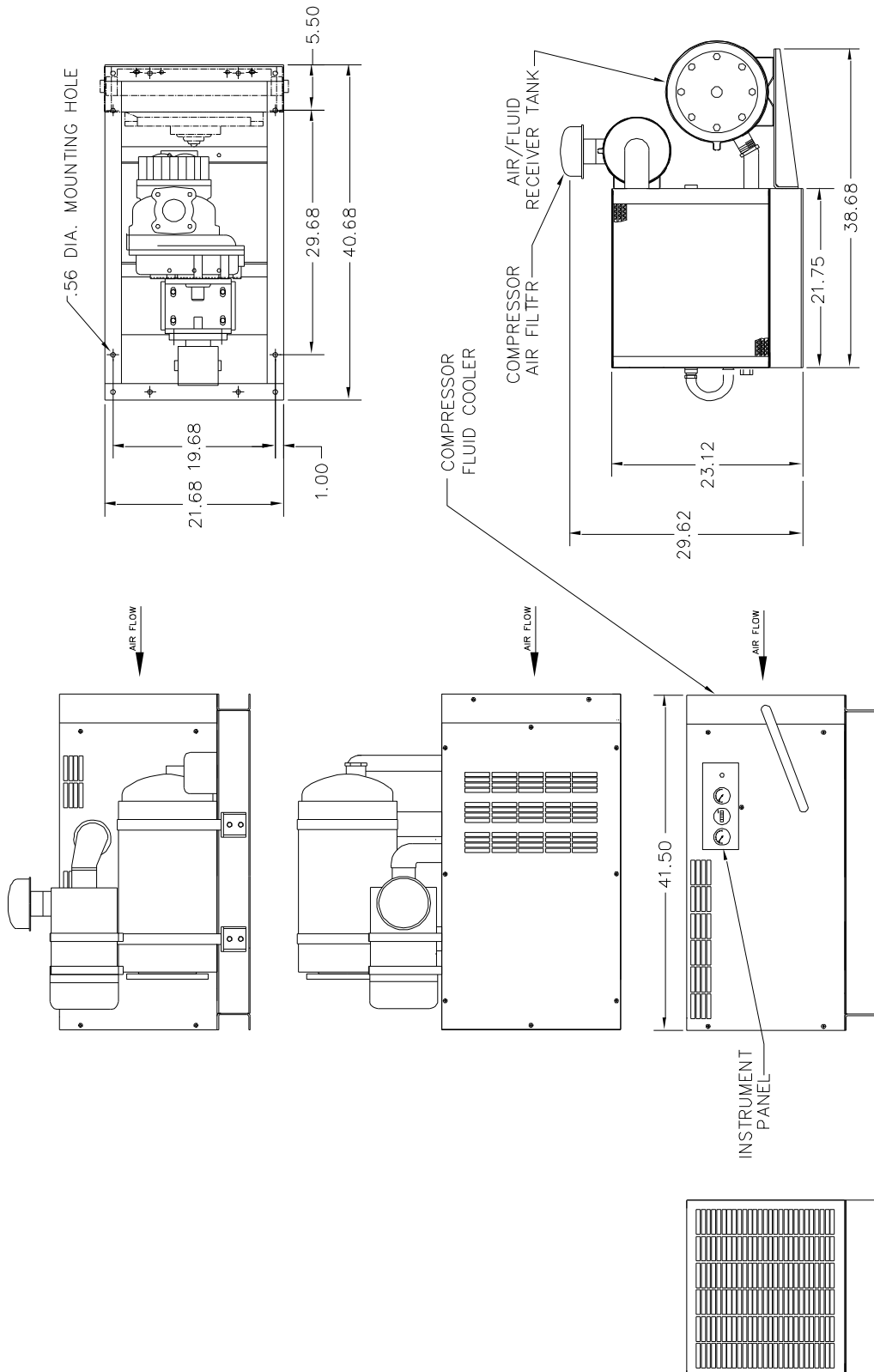



---

# ***SECTION 6: MAINTENANCE***

---

## **6.1 General**

A sound maintenance program is the key to long compressor life. Below is a program that when adhered to, should keep the compressor in top operating condition. See **Section 6.5, Parts Replacement and Adjustment Procedures** for a detailed description of specific compressor system components. Units that have not yet been installed should be stored in a dry, temperature controlled environment. Unit should be recharged with oil if it has been in extensive storage.



**WARNING:** **DO NOT** remove caps, plugs and/or other components when compressor is running or pressurized.

Stop compressor and relieve all internal pressure before doing so.

## **6.2 Daily Operation**

Prior to starting the compressor, it is necessary to check the fluid level in the sump. Should the level be low, simply add the necessary amount. If the addition of fluid becomes too frequent, a simple problem has developed which is causing this excessive loss. See the **Troubleshooting Section (7.2, Troubleshooting Guide)** under *Excessive Fluid Consumption* for a probable cause and remedy.

After a routine start has been made, observe the instrument panel gauge and be sure it monitors the correct reading for that particular phase of operation. After the compressor has warmed up, it is recommended that a general check on the overall compressor and instrument panel be made to assure that the compressor is running properly. Also check the air filter maintenance indicators (if provided).

## **6.3 Maintenance After Initial 50 Hours of Operation**

After the initial 50 hours of operation, a few maintenance requirements are needed to rid the system of any foreign materials. Perform the following maintenance operations to prevent unnecessary future problems.

1. Change the oil filter element.
2. Drain and refill air/oil receiver sump.
3. Inspect intake air filter (change if necessary)

**6.4 Every 500 Hours or Yearly, Whichever Comes First**

**IMPORTANT** – It may be necessary to change at earlier intervals if oil has water contamination or if compressor is operated in poor/dirty environment.

1. Change the oil filter element.
2. Drain and refill air/oil receiver sump.
3. Replace intake air filter.
4. Annually replace separator element (located in air-oil sump).
5. Inspect exterior of front mounted oil cooler, clean if necessary.

**6.5 Parts Replacement and Adjustment Procedures****6.5.1 Compressor Oil Change and Filter Replacement Procedure**

Warm-up compressor for 5 to 10 minutes to warm the fluid. Shut the compressor off and relieve all internal pressure before proceeding. Drain the fluid sump by removing the plug at the bottom of the sump tank. Change the compressor fluid and replace the fluid filter element. For element replacement see procedure for servicing the fluid filter in this section. Fill the sump with fluid according to specifications in **Section 3**.

**6.5.1.1 Compressor Oil Change Procedure**

**IMPORTANT!** Ensure the vehicle is parked on a level surface before performing this procedure. Refer to **Figure 6-1** and the following instructions:

1. Run the compressor five to ten minutes to warm the oil.
2. Relieve all internal compressor system pressure (open service valves), and allow the oil to settle.
3. Remove the receiver tank drain plug, located on the tank bottom, and drain into an oil drain pan.
4. Replace and seat the drain plug after all compressor oil has been drained.
5. Refill the receiver tank with three gallons of Vanair® Vanguard™ Premium Synthetic Oil.
6. Run the compressor for a few moments to circulate new system oil.
7. Check the receiver tank oil level in the sight glass (level should be at the sight glass mark, with the compressor off). Add Vanair Vanguard Premium Synthetic Oil as needed (**DO NOT** overfill the tank).

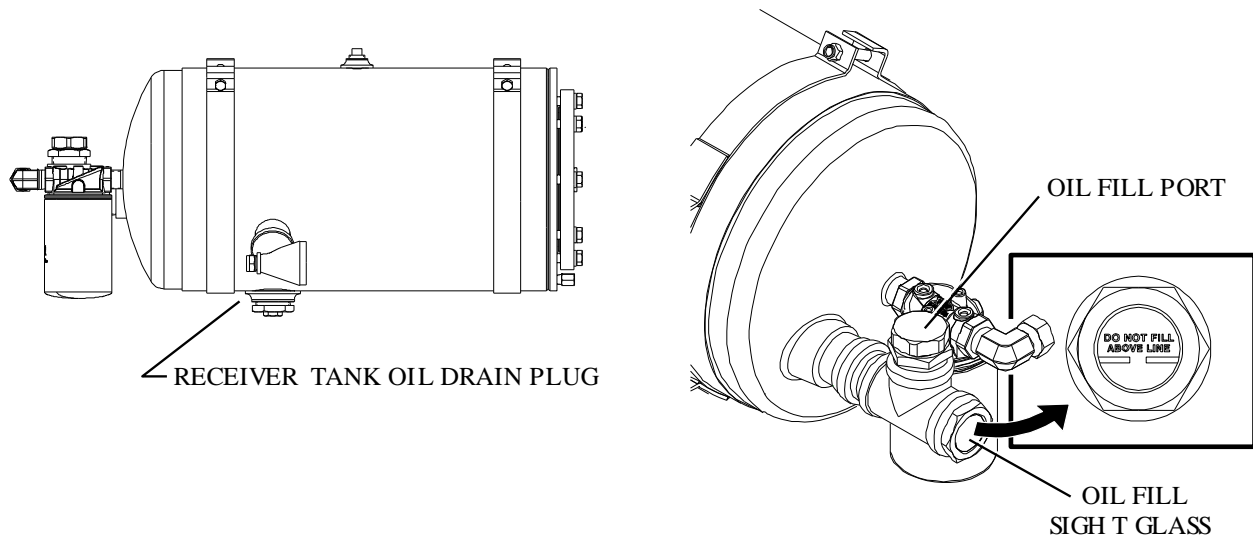

*Figure 6-1: Compressor Oil Fill and Tank Drain Ports*

**6.5.1.2 Compressor Oil Filter Element Replacement**

Refer to *Figure 6-2*.

1. Using a strap wrench, remove the old element and gasket.
2. Clean the gasket seating surface.
3. Apply a light film of fluid to the new gasket.
4. Hand tighten the new element until the new gasket is seated in the gasket groove.
5. Continue tightening the element by hand an additional 1/2 to 3/4 turn.
6. Restart the compressor and check for leaks.

**IMPORTANT:** To minimize the possibility of filter element rupture, it is important that only replacement elements identified with the Vanair name, logo and appropriate part number be used. **DO NOT** use substitute elements. This is due to the fact that such substitution may have inadequate or questionable working pressure ratings.

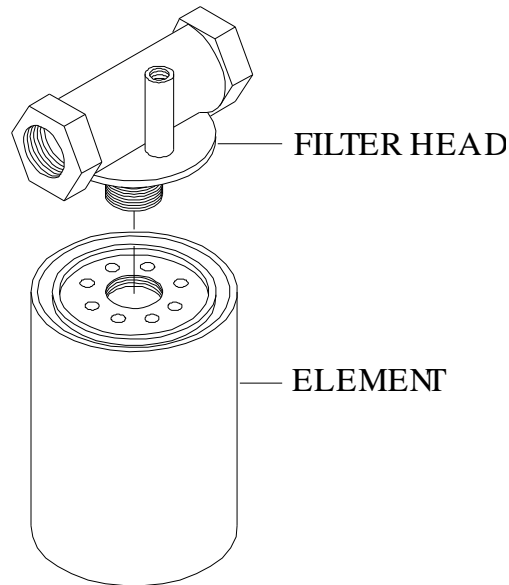
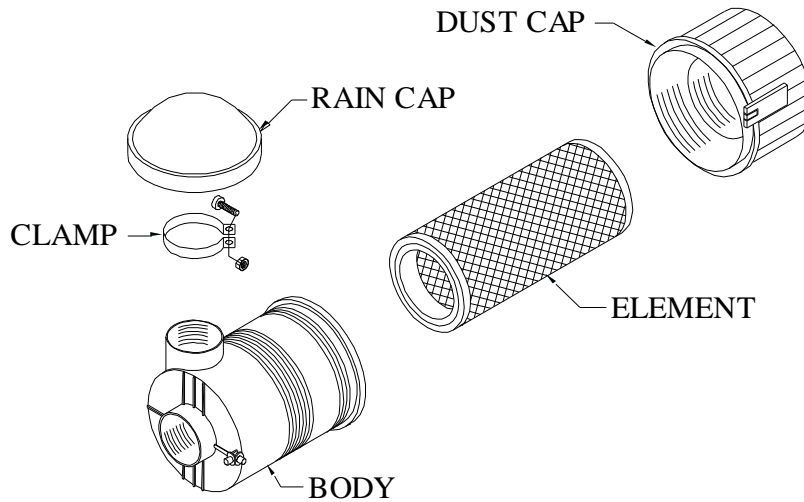

*Figure 6-2: Compressor Oil Filter (Replacement Element P/N 261991)*

### **6.5.2 Air Filter Maintenance**

Refer to *Figure 6-3*. The air filter supplied with your compressor is a two-stage system which offers more than adequate filtration. The air filter should be inspected periodically to maintain maximum compressor protection and filter service life. These inspections should be made:

1. Inspect the air transfer duct work between the air filter and compressor unit to be sure all clamps and joints are tight and there are no cracks in the ducting.
2. The air filter mounting clamps and bolts must be tight to hold the air cleaner securely.
3. Check the rain cap to make sure it is sealing 360° around the air cleaner body.
4. Inspect for dents and damage to the air filter. The end cap (dust cap) of the filter is removable and should be emptied of dirt particles every 100 hours.
5. Check the filter more frequently if used under extreme conditions. The air filter element is a cleanable type and should be serviced in accordance with the following instructions.



*Figure 6-3: Compressor Air Filter (Replacement Element P/N 263931)*

#### **6.5.2.1 Air Filter Element Replacement**

1. Loosen the clamp which secures the rain cap to the body and remove the cap.
2. Remove the rubber baffle from inside the dust cap and empty all dirt particles.
3. Unscrew the wingnut from the center post to loosen the element and remove.
4. Clean the body and dust cap with a clean damp cloth inside and out. **DO NOT BLOW DIRT OUT WITH COMPRESSED AIR!**
5. At this time, clean or replace the element (Part No. 263931). Cleaning instructions follow.
6. Install the element back into the body and replace the wingnut. Tighten securely.
7. Replace the rubber baffle into the dust cap and attach the cap to the body.
8. Re-tighten the clamp to secure the filter.

#### **6.5.2.2 Air Filter Element Cleaning**

The air filter element is cleanable by using compressed air. The maximum amount of times that an element should be cleaned is six (6) times; however, the element should be used no longer than a period of one (1) year without changing.

Prior to cleaning an element, check the element for damage. Damaged elements must be replaced.

**6.5.2.2 Air Filter Element Cleaning - *Continued***

When cleaning an element, never exceed the maximum allowable pressures for compressed air (30 psi).

Do not strike the element against any hard surface to dislodge dust. This will damage the sealing surfaces and possibly rupture the element. Never “blow” dirt out of the interior of the filter housing. This may introduce dust downstream of the filter. Instead, use a clean damp cloth. Do not oil the elements.

**6.5.2.3 Cleaning the Air Filter Element with Compressed Air**

When cleaning the element with compressed air, never let the air pressure exceed 30 PSI. Reverse flush the element by directing the compressed air up and down the pleats in the filter media from the “clean side” of the element. Continue reverse flushing until all dust is removed. Should any oil or greasy dirt remain on the filter surface the element should then be replaced. When the element is satisfactorily cleaned, inspect thoroughly prior to installation (See **6.5.2.4, Air Filter Element Inspection**).

**6.5.2.4 Air Filter Element Inspection**

1. Place a bright light inside the element to inspect for damage or leak holes. Concentrated light will shine through the element and disclose any holes.
2. Inspect all gaskets and gasket contact surfaces of the housing. Should faulty gaskets be evident, correct the condition immediately.
3. If the clean element is to be stored for later use, it must be stored in a clean container.
4. After the element has been installed, inspect and tighten, if necessary, all air inlet connections prior to resuming operation.

**6.5.3 Separation Element Replacement**

Refer to **Figure 6-4**. When fluid carry-over is evident after the fluid return line orifice as well as the blowdown valve diaphragm have been inspected and found to be in satisfactory condition, separator element replacement (P/N 260017-001) is necessary. Follow the procedure explained below.

1. Remove all piping connected to the sump cover to allow removal (return line, service line, etc.).
2. Remove the fluid return line from the fitting in the cover.
3. Remove the eight (8) ½- 13 cover bolts and lock washers and lift the cover from the sump.

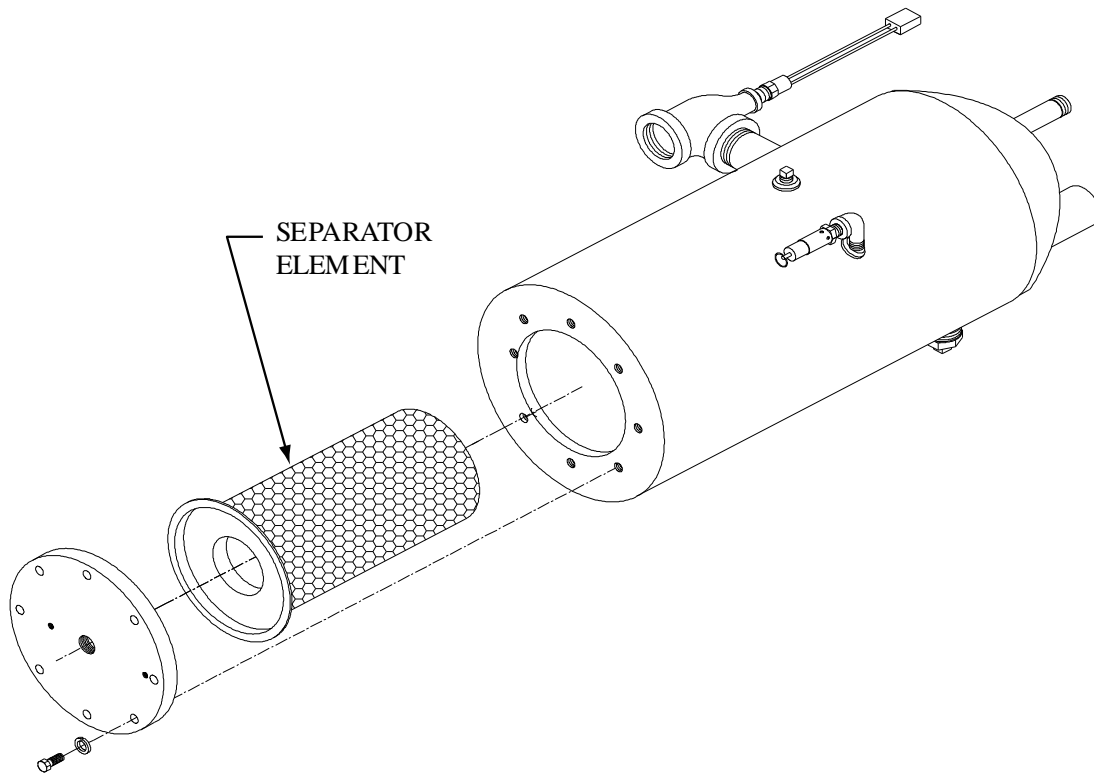

**Figure 6-4: Separator Element** (Replacement Element P/N 260017-001)

4. Remove the separator element.
5. Scrape the old gasket material from the cover and the flange on the sump. Be sure to keep all scrapings from falling inside tank.
6. Install the element with bonded gaskets, making sure the staples in the gaskets come in contact with the metal surface of the bolt ring and cover. **DO NOT** use gasket sealer as it can insulate the staples causing the element not to be properly grounded for operation.
7. Replace the sump cover and bolts. Run the cover bolts in finger tight, then gradually tighten in a crisscross pattern in four to five steps. **ALWAYS** tighten the bolts alternately at opposite sides of the cover. **NEVER** tighten bolts adjacent to each other. Torque bolts to 55 to 75 ft. lbs.
8. Reconnect all piping.
9. Clean the fluid return line and clear the orifice prior to restarting the compressor.

***BLANK PAGE***



# ***SECTION 7: TROUBLESHOOTING***

## **7.1 Troubleshooting**

The information contained in the Troubleshooting chart has been compiled from field report data and factory experience. It contains symptoms and usual causes for the described problems. However, **DO NOT**, assume that these are the only problems that may occur. All available data concerning the trouble should be systematically analyzed before undertaking any repairs or component replacement procedures.

A detailed visual inspection is worth performing for almost all problems. Doing so may prevent damage to the compressor. Always remember to:

1. Check for loose wiring.
2. Check for damaged piping.
3. Check for parts damaged by heat or an electrical short circuit, usually noticeable by discoloration or a burnt odor.

Should your problem persist after making the recommended check, consult your nearest Vanair<sup>®</sup> representative or Vanair Manufacturing, Inc.

## **7.2 Troubleshooting Guide**

<b>SYMPTOM</b>	<b>PROBABLE CAUSE</b>	<b>REMEDY</b>
COMPRESSOR SHUTS DOWN WITH AIR DEMAND PRESENT	Compressor Discharge Temperature Switch is Open	Cooling air flow is insufficient; clean cooler and check for proper ventilation.
		Low fluid sump level; add fluid.
		Dirty compressor fluid filter; change element.
		Electric fan is not functioning.
	Defective discharge temperature switch; check for a short or open circuit to the engine fuel solenoid. Should this check out normal, it could be possible that the temperature switch itself is defective.	
	Circuit Breaker Tripped on Instrument Panel	Reset circuit breaker and check for cause of overload.
COMPRESSOR WILL NOT BUILD UP FULL DISCHARGE	Air Demand is Too Great	Check service lines for leaks or open valves.

<b>7.2 Troubleshooting Guide (Continued)</b>		
<b>SYMPTOM</b>	<b>PROBABLE CAUSE</b>	<b>REMEDY</b>
COMPRESSOR WILL NOT BUILD UP FULL DISCHARGE (CONTINUED)	Dirty Air Filter	Check the filter and change element if required.
	Pressure Regulator Out of Adjustment	Adjust regulator according to control adjustment instructions in the Maintenance section.
	Defective Pressure Regulator	Check diaphragm and replace if necessary.
	Incorrect Compressor Speed	Check & adjust to proper speed.
IMPROPER UNLOADING WITH AN EXCESSIVE PRESSURE BUILD-UP CAUSING PRESSURE RELIEF VALVE TO OPEN	Pressure Regulating Valve is Set Too High	Readjust.
	Leak in Control System Causing Loss of Pressure Signal	Check control lines.
	Defective Pressure Regulating Valve	Repair valve.
	Inlet Valve Jammed	Free or replace valve.
	Defective Pressure Relief Valve	Replace pressure relief valve.
INSUFFICIENT AIR DELIVERY	Plugged Air Filter	Replace.
	Plugged Air/Fluid Separator	Replace separator element and also change compressor fluid and fluid filter at this time.
	Defective Pressure Regulator	Adjust or repair.
	Engine Speed Too Low	Readjust engine speed.
EXCESSIVE COMPRESSOR FLUID CONSUMPTION	Clogged Return Line	Clear orifice.
	Defective Shutdown Blowdown Valve Diaphragm	Replace diaphragm.
	Leak in the Lubrication System	Check all pipes, connections and components.
	Separator Element Damaged or Not Functioning Properly	Change separator element.
	Fluid Sump Overfilled	Drain to proper level.
COMPRESSOR OVERHEATING	Dirty Fluid Cooler Core	Clean core thoroughly.
	Plugged Fluid Cooler Tube (Internal)	Clean tube thoroughly.
	Low Sump Fluid Level	Fill.
	Plugged Compressor Fluid Filter	Change element.
	Electric Fan is Not Functioning	Check wires, fan motor, & fan switch for fault & replace faulty part.

# ***SECTION 8: ILLUSTRATIONS AND PARTS LIST***

## **8.1 Procedure for Ordering Parts**

Parts should be ordered from the nearest Vanair Representative or the Representative from whom the compressor was purchased. If, for any reason, parts cannot be obtained in this manner, contact the factory directly at the address or phone numbers below.

When ordering parts always indicate the **Serial Number** of the compressor package. This can be obtained from the Bill of Lading for the compressor or from the Serial Number Plate located on the compressor (*Figure 8-1*).

**VANAIR MANUFACTURING,  
INC.**

**10896 West 300 North  
Michigan City, IN 46360**

**Phone: (219) 879-5100  
(800) 526-8817**

**Service Fax: (219) 879-5335  
Parts Fax: (219) 879-5340  
Sales Fax: (219) 879-5800**

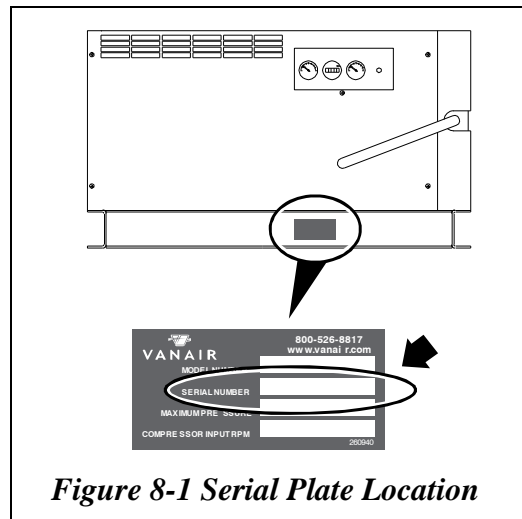

<b>Table 8A: Recommended Spare Parts List</b>		
<b>Key No.</b>	<b>Description</b>	<b>Part Order No.</b>
1	Oil Filter Replacement Element	261991
2	Air Filter Replacement Element	264266
3	Air/Oil Separator Replacement Element	260017-001
4	Vanguard™ Premium Oil <sup>1</sup>	264626-4PACK

<sup>1</sup> Quantity of four (4) x one (1) gallon containers. Use only Vanair® Vanguard™ Premium Synthetic Oil and Genuine Vanair Parts. Inspect and replace damaged components before operation. Substituting non-Vanguard™ Oil or non-genuine Vanair filter components **WILL VOID THE COMPRESSOR WARRANTY!**

**8.2 Discharge System**

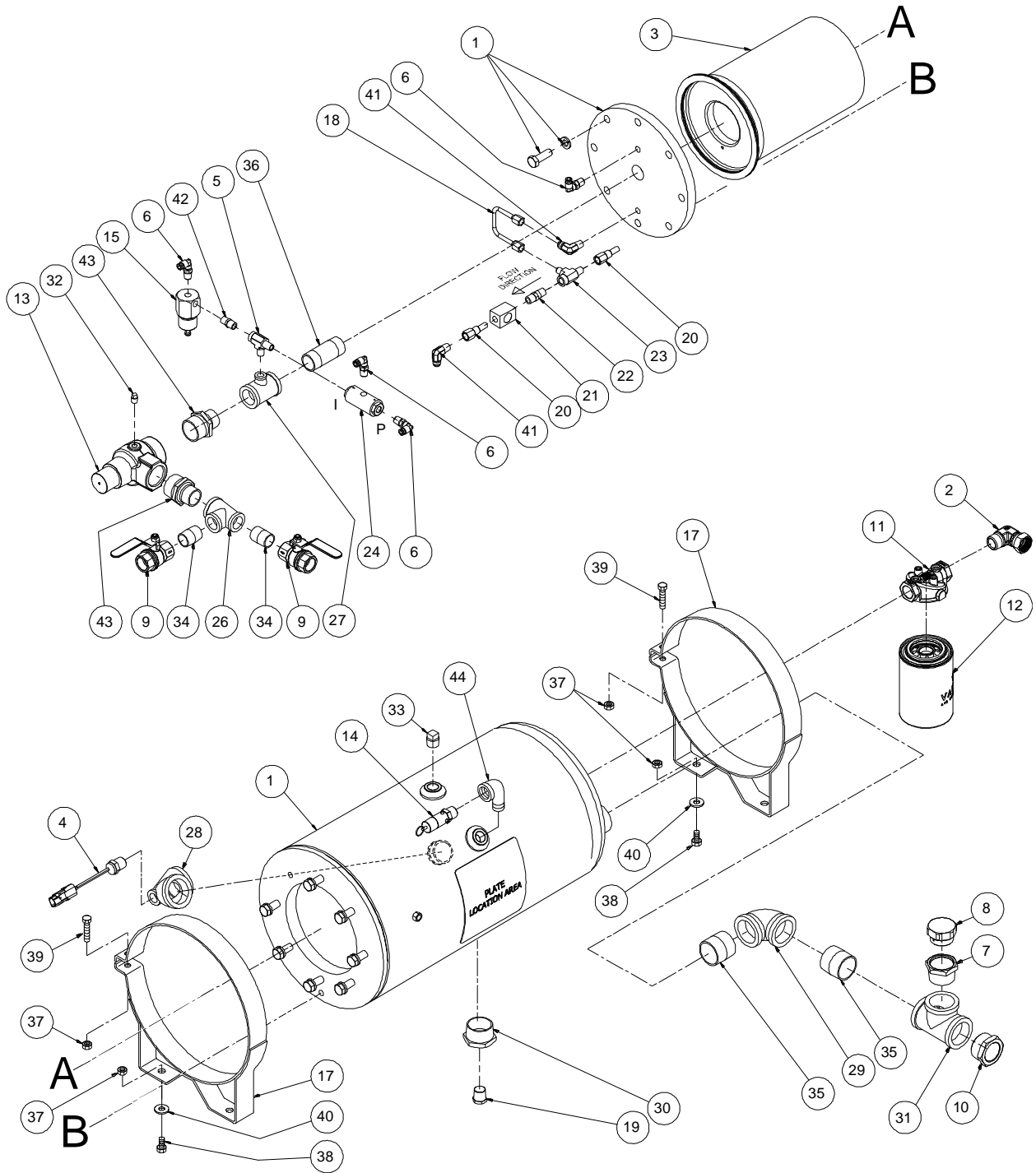

**8.2 Discharge System**

<b><u>KEY</u></b>	<b><u>DESCRIPTION</u></b>	<b><u>PART NUMBER</u></b>	<b><u>QTY</u></b>
1	Receiver, Air/Oil Horizontal	047331-001	1
2	Elbow, Swivel 90 Deg. 3/4 Pipe x 3/4 Pipe	048429	1
3	Element, Air/Oil Separator	260017-001	1
4	Valve, Relief, 200 PSI, 1/2" npt	270853	1
5	Tee, Pipe Female Street 1/4	260848-102	1
6	Elbow, 90 Deg. Push On 1/4t x 1/4p	261310	4
7	Adapter, Fill	261975	1
8	Plug, O-ring 1-1/4	261981	1
9	Valve, Service 3/4	261982	2
10	Glass, Sight Oil Level 1-1/2	261984	1
11	Head, Oil Filter 3/4 npt	261990	1
12	Element, Oil Filter	261991	1
13	Valve, 1 1/4 NPT Min. Press. Check	262004	1
14	Switch, Temperature 185 Deg. NO	263704	1
15	Valve, Regulator, 6:1	262047	1
16	Channel, Receiving Mtg.	262251	2
17	Band, Mounting 12"	262252	2
18	Tube, Separator Drain w/ Fitting	262270	1
19	Plug, Pipe Hex 1/2 NPT	263293	1
20	Filter, Orifice, .047 Dia., 1/4 FPT x 1/4 MPT	269788	2
21	Sight Glass, 1/4 FPT	269789	1
22	Valve, Check 1/4 NPT Male	269893	1
23	Tee, 1/4 MPT x 1/4 FPT x 1/4 MJIC	270115	1
24	Valve, Blowdown 1/4 Piston	270807	1
25	Elbow, Pipe Street 1/2	801115-020	1
26	Tee, Reducing 1 x 3/4 x 3/4	802904-033	1
27	Tee, Reducing 1 x 1 x 1/4	802904-041	1
28	Tee, Reducing 1 1/2 x 1/2 x 1 1/2	802906-026	1
29	Elbow, Pipe 90 Deg. Street 1/2	801115-020	1
30	Bushing, Reducing 1-1/2 x 1/2	804106-020	1
31	Tee, Pipe galv 1 1/2	804415-060	1
32	Plug, Pipe 1/8	807800-005	1
33	Plug, Pipe 1/2	807800-020	1
34	Nipple, Pipe XS Close 3/4	822212-000	2
35	Nipple, Pipe XS Close 1 1/2	822224-000	1
36	Nipple, Pipe Galv 1 x 3	823116-030	1
37	Nut, Hex Locking 3/8-16	825506-198	6
38	Capscrew, Hex gr5	829106-150	4
39	Capscrew, Hex GR5 3/8-16 x 2	829106-200	2
40	Washer, Flat 3/8"	838206-071	4
41	Elbow, 37FL/90M #06 x 1/4	860206-025	2
42	Nipple, Pipe Hex 1/4 x 1/4	860404-025	1
43	Nipple, Hex Red 1 1/4x 1	861620-100	2
44	Elbow Pipe 90 Deg. Street 1/2	801115-002	1

**PLEASE NOTE: WHEN ORDERING PARTS, INDICATE MACHINE SERIAL NUMBER**

**8.3 Enclosure**

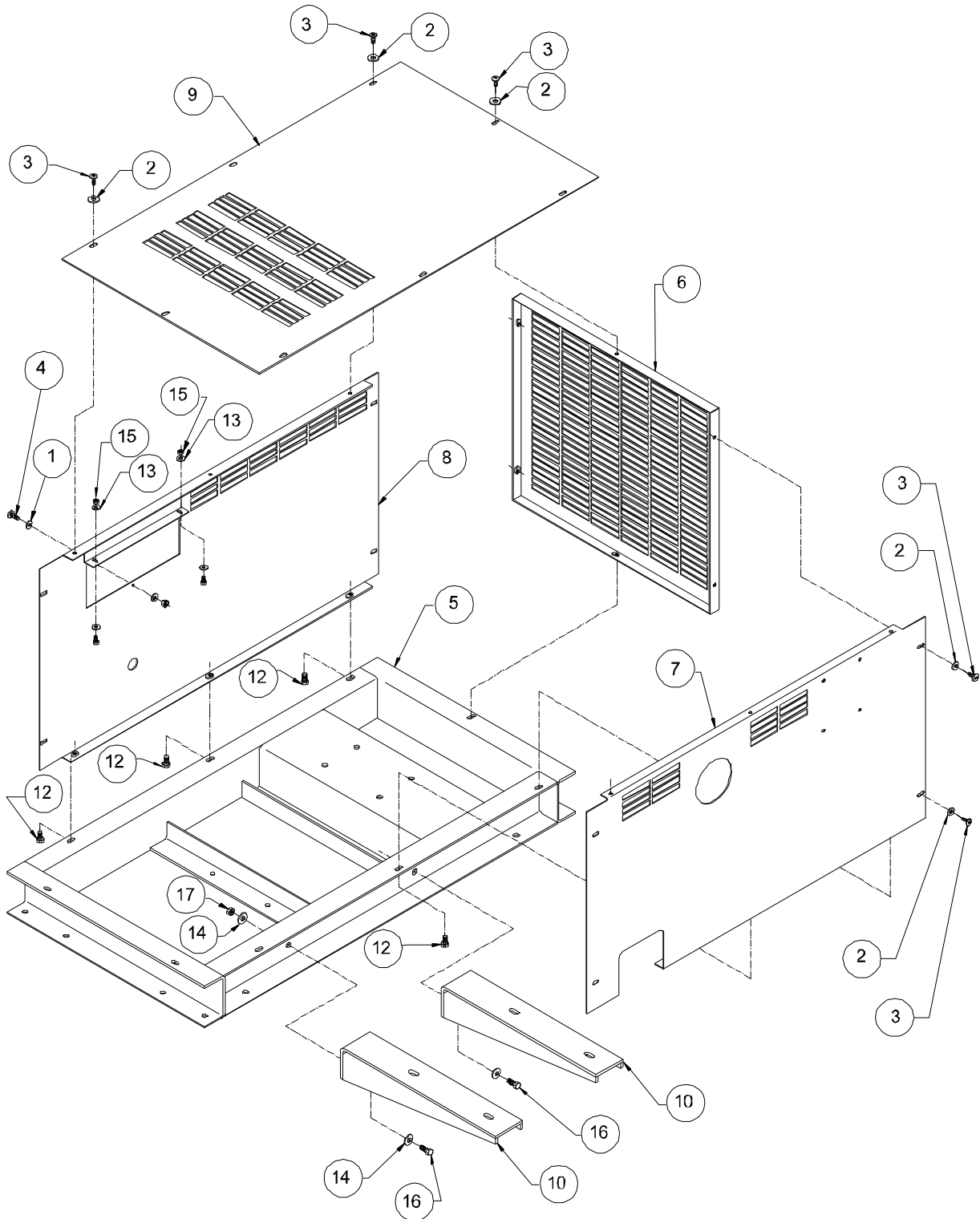

**8.3 Enclosure**

<b><u>KEY</u></b>	<b><u>DESCRIPTION</u></b>	<b><u>PART NUMBER</u></b>	<b><u>QTY</u></b>
1	Washer, Flat Nylon 1/4	262704	1
2	Washer, Flat Nylon 5/16	262943	14
3	Screw, Truss HD 5/16 - 18 x 3/4	262945	14
4	Screw, Truss HD 1/4 x 3/4	262953	1
5	Frame, Assembly ADHD-EC	263464	1
6	Panel, End	263469	1
7	Panel, Side R.H.	263471	1
8	Panel, Side L.H.	263472	1
9	Panel, Roof	263473	1
10	Angle, Receiver Tank Mtg.	263484	2
11	Capscrew, Hex HD 1/4 - 20 x 3/4	829104-075	2
12	Capscrew, Hex HD 5/16 - 18 x 3/4	829705-075	6
13	Washer, Flat 1/4	838204-071	5
14	Washer, Flat 1/2	838208-112	8
15	Nut, Locking Hex 1/4 - 20	825504-145	3
16	Capscrew, Hex HD 1/2 - 13 x 2	829408-200	4
17	Nut, Locking Hex 1/2 - 13	825508-262	4

---

**PLEASE NOTE: WHEN ORDERING PARTS, INDICATE MACHINE SERIAL NUMBER**

**8.4 Instrument Panel**

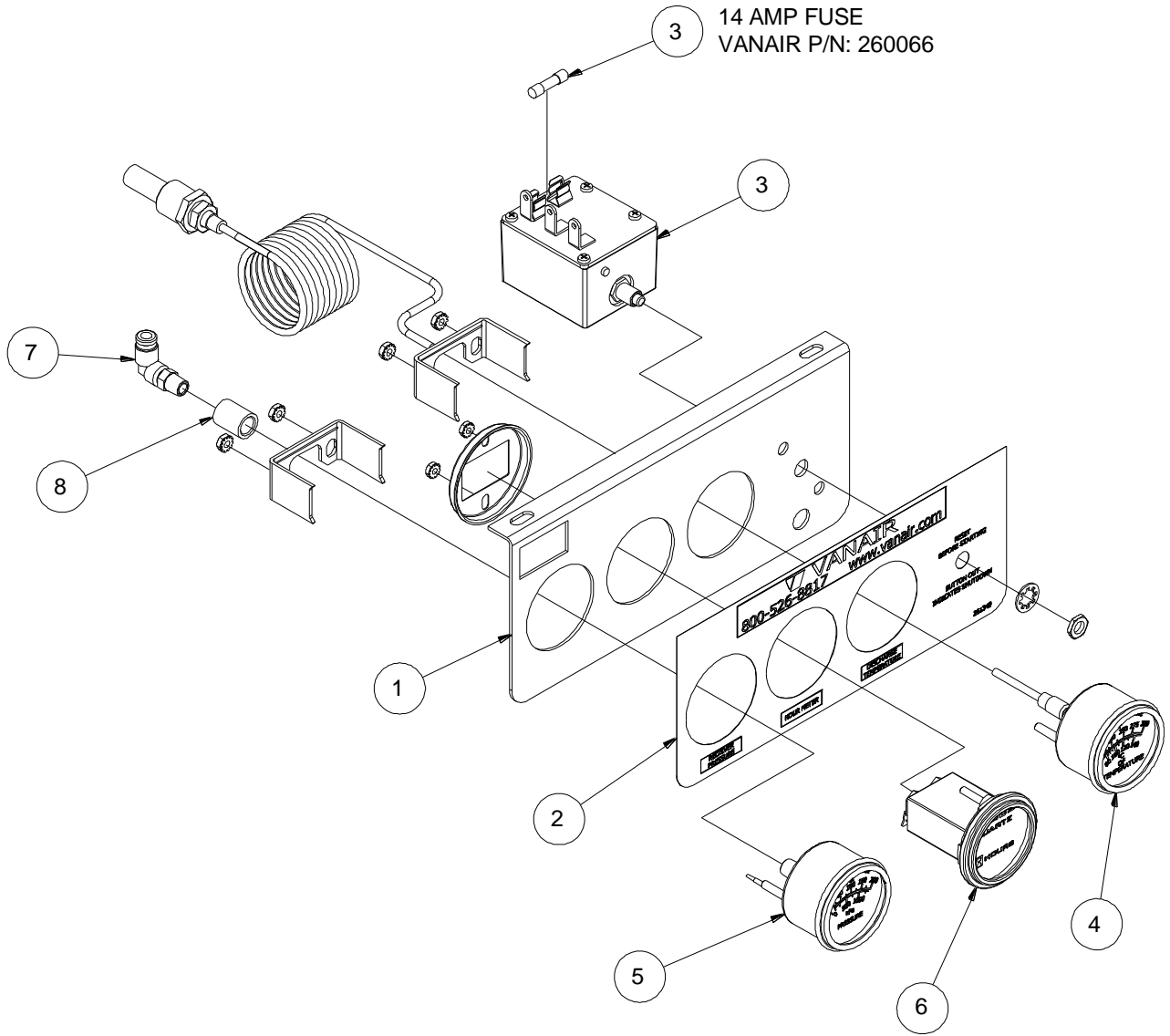



**8.4 Instrument Panel**

<b><u>KEY</u></b>	<b><u>DESCRIPTION</u></b>	<b><u>PART NUMBER</u></b>	<b><u>QTY</u></b>
1	Panel, Gauge	261251	1
2	Decal, Panel Overlay	261349	1
3	Switch, High Temp. Shutdown	260625	1
4	Gauge, Temperature	266331	1
5	Gauge, Pressure	261974	1
6	Gauge, Hour Meter	040035	1
7	Elbow, 1/4T x 1/8P Push-on	261309	1
8	Coupling, Pipe Galv	806230-005	1
NS	Relay, NO/NC		
	• (12V)	260246	1
	• (24V)	265182	1

---

**PLEASE NOTE: WHEN ORDERING PARTS, INDICATE MACHINE SERIAL NUMBER**

**8.5 Inlet Valve Assembly**

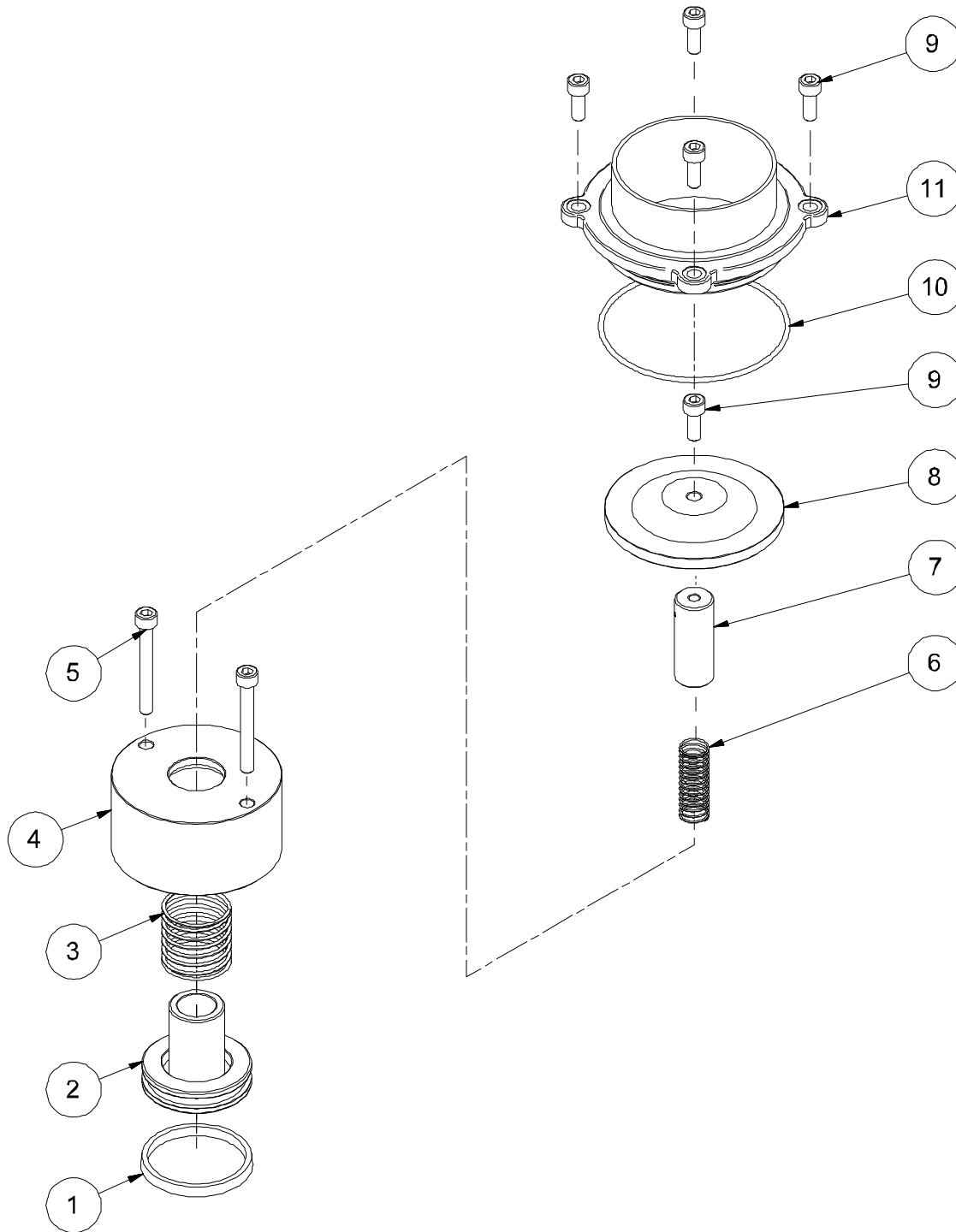

**8.5 Inlet Valve Assembly**

<b><u>KEY</u></b>	<b><u>DESCRIPTION</u></b>	<b><u>PART NUMBER</u></b>	<b><u>QTY</u></b>
1	Seal, Inlet Valve	265400-001	1
2	Piston, Inlet Valve	265400-002	1
3	Spring, Piston Inlet Valve	265400-003	1
4	Housing, Piston Inlet Valve	265400-004	1
5	Screw, Socket Head M6 x 50	265400-005	2
6	Spring, Inlet Check	265400-006	1
7	Stem, Inlet Valve	265400-007	1
8	Valve, Inlet Check	265400-008	1
9	Screw, Socket Head M6 x 16	265400-009	5
10	O-Ring, Viton 3-1/4 x 3/32	265400-010	1
11	Adapter, Inlet Valve	265400-011	1
NS	Tube, Gasket Cement	265400-012	1
NS	Tube, Threadlock	265400-013	1
NS	Kit, Inlet Repair (Consisting of Items #1, 3, 5, 6, 10, 12, &13)	265400-014	1

---

**PLEASE NOTE: WHEN ORDERING PARTS, INDICATE MACHINE SERIAL NUMBER**

**8.6 Oil Cooling System (Electric) 125 - 185 CFM**

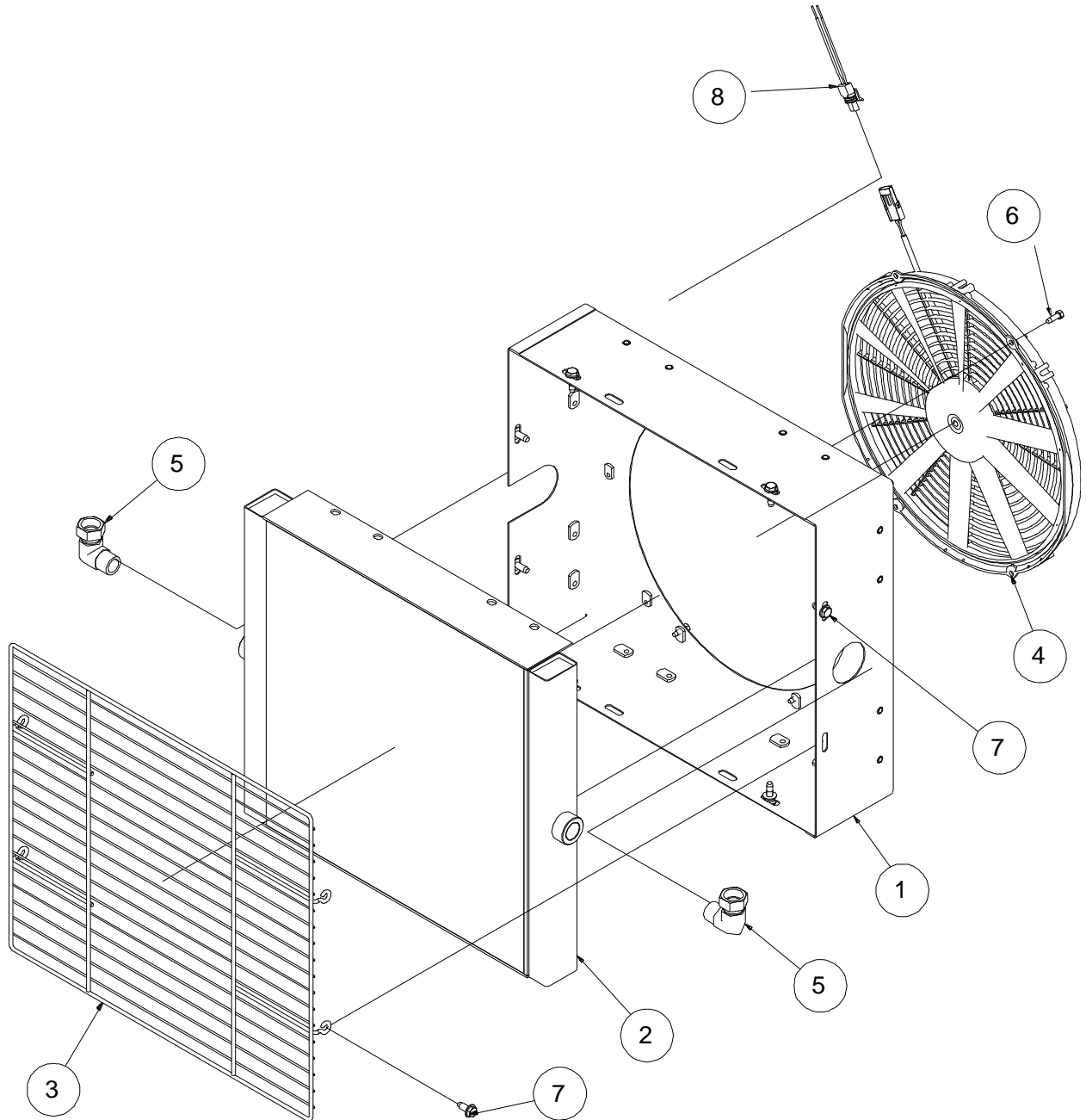

**8.6 Oil Cooling System (Electric) 125 - 185 CFM**

<b><u>KEY</u></b>	<b><u>DESCRIPTION</u></b>	<b><u>PART NUMBER</u></b>	<b><u>QTY</u></b>
1	Shroud, Cooler	262109	1
2	Cooler, Oil 125-185 CFM	261992	1
3	Guard, Cooler 125/185 EC	261968	1
4	Fan and Motor Assy		
	• 12V	264856	1
	• 24V	265057	1
5	Elbow, Swivel 90 3/4 FPT x 3/4 MPT	048429	2
6	Screw, Hex Self Thread 1/4 x 3/4	834204-075	4
7	Screw, Ser Washer 5/16-18 x 0.75	829705-075	12
8	Harness, Wire	266607	1

---

**PLEASE NOTE: WHEN ORDERING PARTS, INDICATE MACHINE SERIAL NUMBER**

**8.7 Above Deck – Compressor, Air Inlet and Parts**

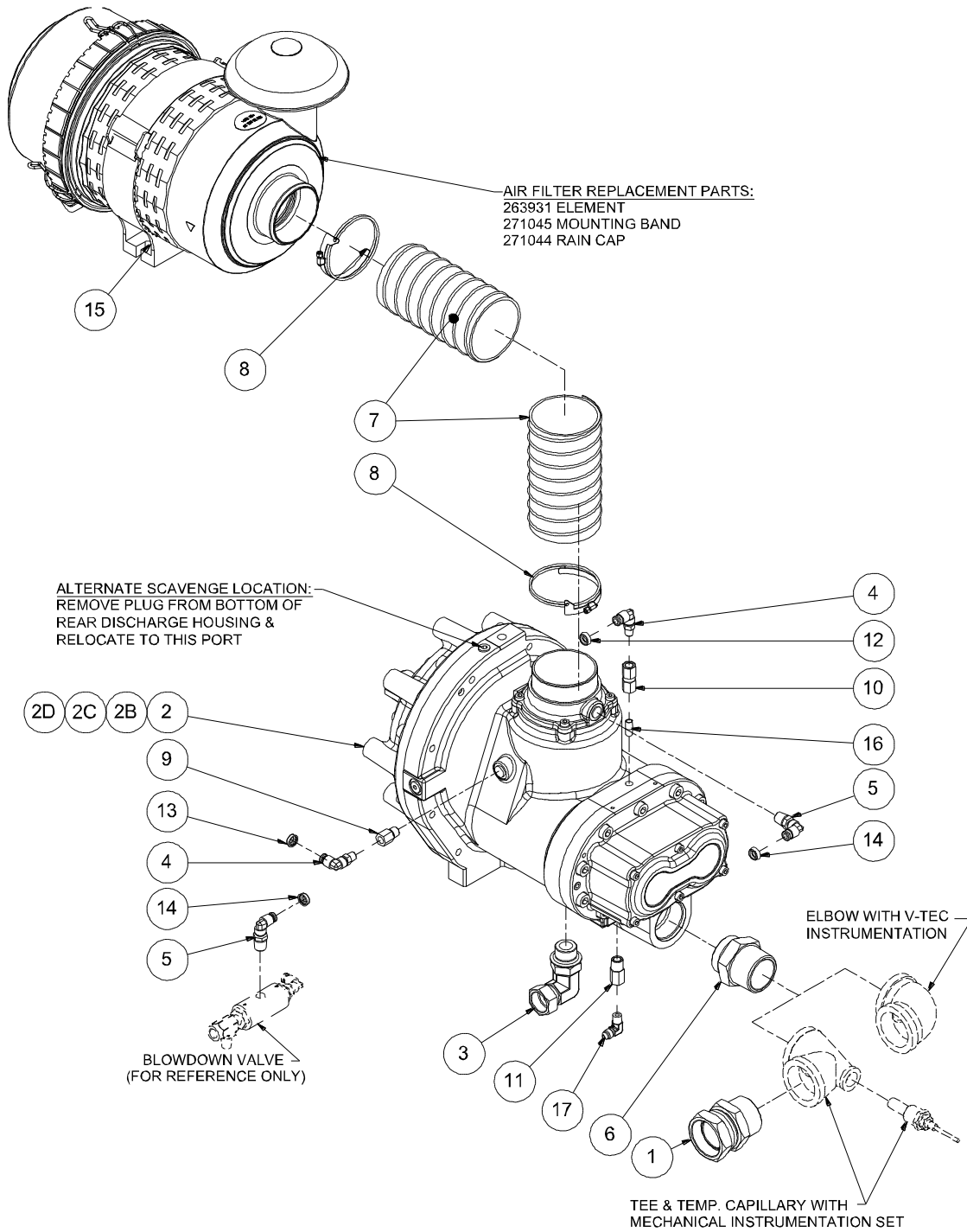

**8.7 Above Deck – Compressor, Air Inlet and Parts**

<b><u>KEY</u></b>	<b><u>DESCRIPTION</u></b>	<b><u>PART NUMBER</u></b>	<b><u>QTY</u></b>
1	Adapter, Swivel 1-1/2"	040292	1
2	Compressor, 2.56 Ratio Standard Short Shaft	250187-301	1
2B	Compressor, 3.95 Ratio Standard Short Shaft	250187-303	1
2C	Compressor, 3.04 Ratio Standard Short Shaft	250187-312	1
2D	Compressor, 3.95 Ratio High Strength Short Shaft	250200-818	1
2E	Compressor, 2.56 Ratio High Strength Short Shaft	250202-291	1
3	Elbow, Sae O-Ring X Female Pipe Swivel	260105-009	1
4	Elbow, 1/4t X 1/8p Push-On	261309	2
5	Elbow, 90 Deg. Push On 1/4t X 1/4p	261310	2
6	Adapter, 1-1/2" Pipe X 1-1/2 O-Ring	261938-016	1
7	Tubing, Flex 3" Air Intake	262090	8.3
8	Clamp, Hose 3"	263714	2
9	Adapter, #4 Msae O-Ring X 1/8 Fnpt	263868-004	1
10	Valve, Inline Check 1/8p	264103	1
11	Bushing. 1/4 P X 1/8 P Extended	265437	1
12	Cover,Colored Push Loc Orange	269118-002	1
13	Cover,Colored Push Loc Red	269118-003	1
14	Cover,Colored Push Loc Yellow	269118-007	2
15	Filter, Air 8" Mh 3" Outlet	271043	1
16	Nipple, Pipe 1/8 X Close	822202-000	1
17	Elbow, 37fl/90m #04 X 1/8	860204-012	1

---

**PLEASE NOTE: WHEN ORDERING PARTS, INDICATE MACHINE SERIAL NUMBER**

**8.8 Above Deck – Hydraulic Drive**

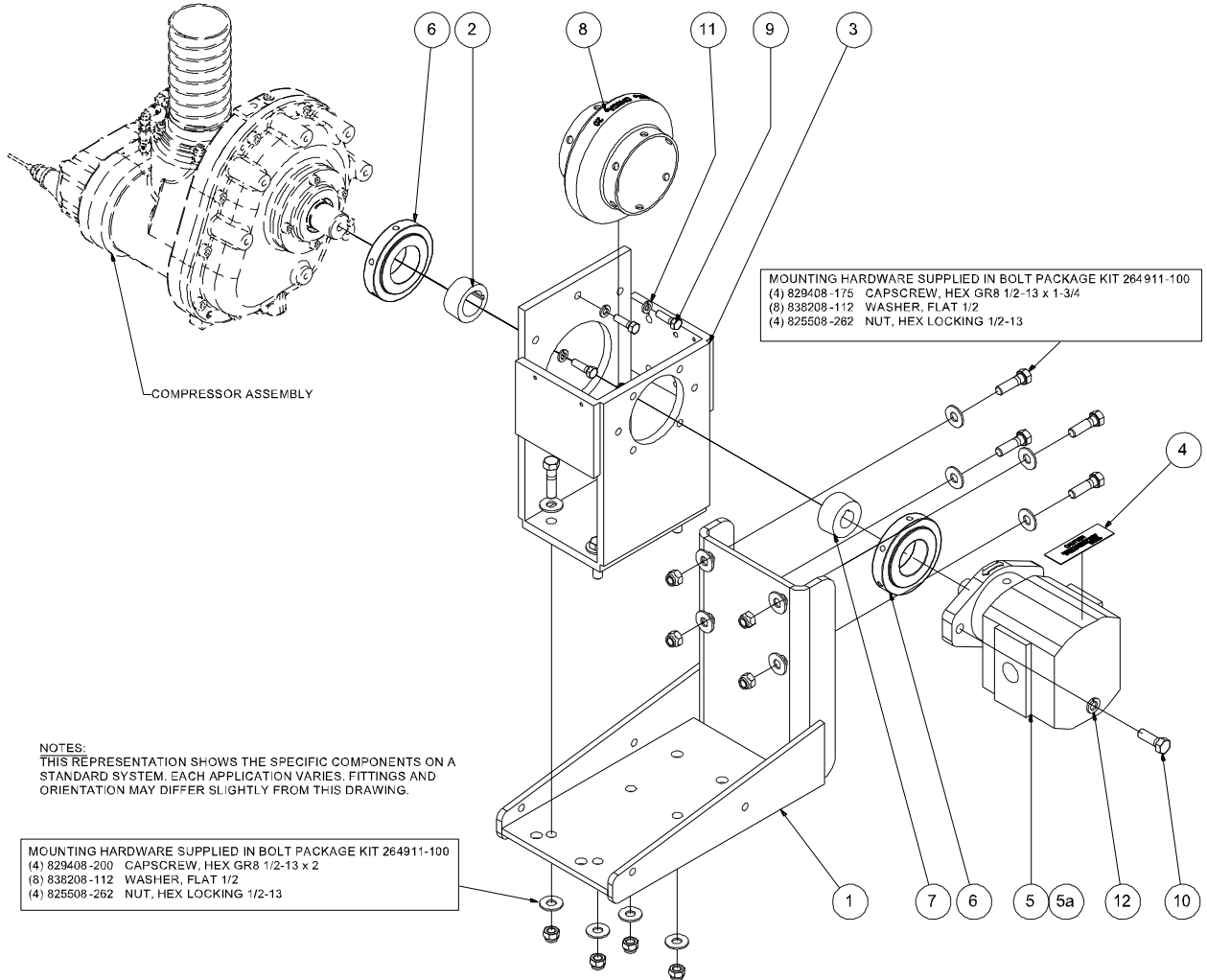



**8.8 Above Deck – Hydraulic Drive**

<b><u>KEY</u></b>	<b><u>DESCRIPTION</u></b>	<b><u>PART NUMBER</u></b>	<b><u>QTY</u></b>
1	Frame, Compressor Mounting	012745	1
2	Bushing, Taper Bore 1610 1" Bore	049853	1
3	Support, Comp/Hyd Motor	263052	1
4	Decal, Caution O-Ring Fitting	263252	1
5	Motor, Hyd 3.2 Cid	263365	1
5a	Motor, Hyd 4.5 Cid	263366	1
Ns	Kit, Bolt Package	264911-100	1
6	Hub, Taper Lock E20 Htl Rexnord	408012	2
7	Bushing, Taper Bore 1610 1" Bore	408014	1
8	Element, Coupling We20	408975	1
9	Capscrew, Hex Gr8 3/8-16 X 1 1/4	829406-125	5
10	Capscrew, Hex Gr8 1/2-13 X 1 1/2	829408-150	2
11	Washer, Lock 3/8	838506-094	5
12	Washer, Lock 1/2	838508-125	2

---

**PLEASE NOTE: WHEN ORDERING PARTS, INDICATE MACHINE SERIAL NUMBER**

**8.9A Decal Locations – 1 of 2**

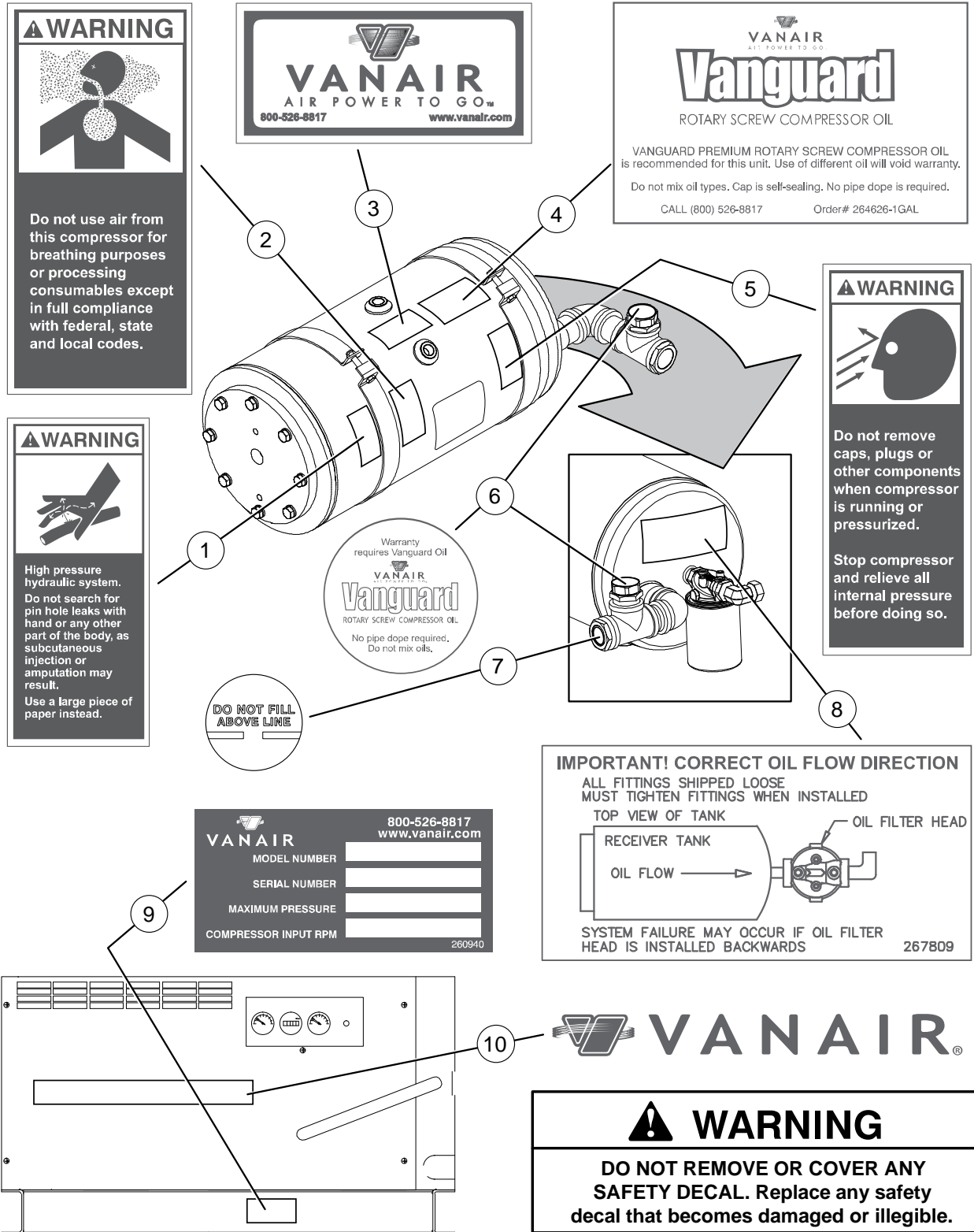

**8.9B Decal Locations – 2 of 2**

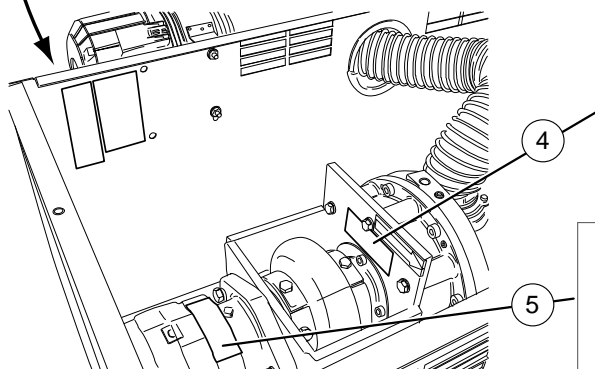
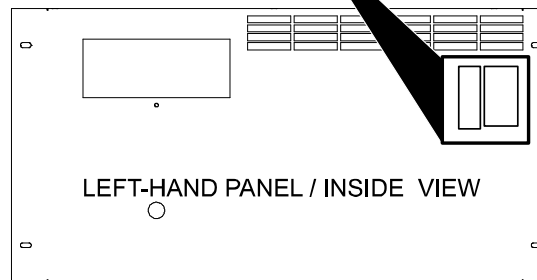
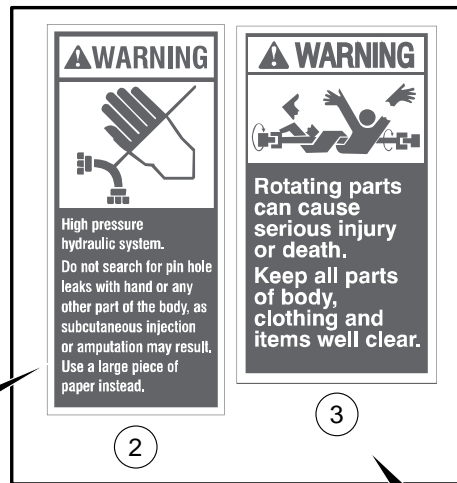
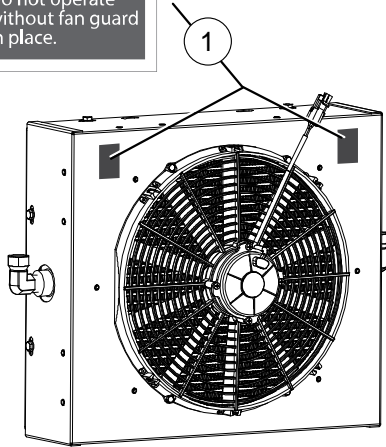

**BLANK PAGE**

Vanair Manufacturing, Inc.  
10896 West 300 North  
Michigan City, IN 46360  
219-879-5100

## INSTALLATION/TEST RECORD

Distributor \_\_\_\_\_ End User \_\_\_\_\_  
\_\_\_\_\_  
\_\_\_\_\_

Receiver S/N \_\_\_\_\_ Serial Number \_\_\_\_\_

Air End S/N \_\_\_\_\_ Vin Number \_\_\_\_\_

Split Shaft S/N \_\_\_\_\_

Locations:

Split Shaft Location (inches from cab) \_\_\_\_\_

Air End/PTO: Left/Right/Extension Bracket Notes \_\_\_\_\_

Receiver Tank: Left/Right Notes \_\_\_\_\_

Instrument Panel: Ship Loose/Inside Cab/Under Hood/Other \_\_\_\_\_

Air Cleaner: Ship Loose/Under Hood/Inside Body

Notes: \_\_\_\_\_

Cooler: Ship Loose/Front of Body/Van Wall/None Electric/

Notes: \_\_\_\_\_

Generator Panel: N/A Location: \_\_\_\_\_

Service Valve Locations: \_\_\_\_\_

Muffler Modifications: \_\_\_\_\_

Notes: \_\_\_\_\_

Auxiliary Equipment: Hose Reels/Tool Lifter/Generator/Other \_\_\_\_\_

Truck Date: Make \_\_\_\_\_ Model \_\_\_\_\_ Year \_\_\_\_\_

GVW \_\_\_\_\_ Engine \_\_\_\_\_ Trans \_\_\_\_\_

Wheel Base \_\_\_\_\_ C.A. \_\_\_\_\_

Compressor Data: Size \_\_\_\_\_ Mounting: Above/Below

PTO Data: Make \_\_\_\_\_ Model \_\_\_\_\_ Control Type \_\_\_\_\_

Drivelines \_\_\_\_\_ U-Joints \_\_\_\_\_

Speeds: \_\_\_\_\_ Idle \_\_\_\_\_ Full Load \_\_\_\_\_

Engine: \_\_\_\_\_ RPM \_\_\_\_\_ RPM \_\_\_\_\_

Compressor: \_\_\_\_\_ RPM \_\_\_\_\_ RPM \_\_\_\_\_ CFM \_\_\_\_\_ Pressure

Tested \_\_\_\_\_ Date \_\_\_\_\_

**BLANK PAGE**

**BLANK PAGE**



# VANAIR®

AIR POWER TO GO™

**Vanair Manufacturing, Inc.**

**10896 West 300 North**

**Michigan City, IN 46360**

**Phone: (219) 879-5100**

**(800) 526-8817**

**Service Fax: (219) 879-5335**

**Parts Fax: (219) 879-5340**

**Sales Fax: (219) 879-5800**

**[www.vanair.com](http://www.vanair.com)**

Printed in the U.S.A.

Specifications Subject to Change

Without Prior Notice

050213-002